

 **Bulk Seed Handling**

Seed Chariot® 2-Box Tender  
Model 1020

Part No. 2000827

### Foreword



This symbol identifies important safety messages. When you see it, read the message that follows and be alert to the possibility of personal injury.

Remember, safety instructions stated in this manual are for your protection. Read them carefully and follow them closely when working around or using this machine.

Read and study this manual completely before attempting to operate this implement. Take this manual to the field for handy reference when operating, adjusting, or servicing your machine.

When referenced, “Right-Hand” (RH) and “Left-Hand” (LH) side of the machine are determined by standing behind the machine and facing in the direction of travel.



## Product Information

All products manufactured by Unverferth Mfg. Co., Inc. are warranted to be free from material and workmanship defects for one full year from time of consumer delivery. Your local dealer will gladly assist you with any warranty questions.

Please fill out and retain this portion for your records. The serial number plate is located on the frame as shown below.

Purchase Date \_\_\_\_\_ Model \_\_\_\_\_ Serial No. \_\_\_\_\_

Dealer \_\_\_\_\_ City \_\_\_\_\_

Dealer Contact \_\_\_\_\_ Phone \_\_\_\_\_

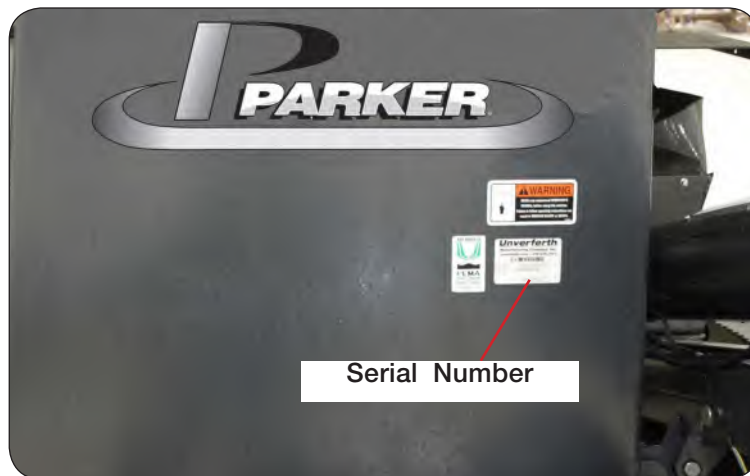

## IMPORTANT

*The information, specifications, and illustrations in the manual are on the basis of information available at the time it was written. Due to continuing improvements in the design and manufacture of Killbros products, all specifications and information contained herein are subject to change without notice.*

## Table of Contents

### Section I Safety

General Hazard Information .....	1-2
Safety Decals .....	1-3
Following Safety Instructions .....	1-4
Before Servicing.....	1-4
Before Operating.....	1-5
During Operation.....	1-5
Before Transport.....	1-6
During Transport.....	1-6
Prepare for Emergencies .....	1-7
Wearing Protective Equipment.....	1-7

### Section II Set Up

Pre-Delivery Checklist .....	2-2
Seed Chariot Assembly.....	2-3
Assemble Hitch to Undercarriage.....	2-3
Raising Conveyor/Auger to Working Position.....	2-4
Optional Scale Package (#2000621).....	2-5
Optional Electric Raise/Lower for Conveyor .....	2-7
Optional AG Decal Package Placement.....	2-8

FOR TORQUE INFORMATION, PLEASE REFER TO THE MAINTENANCE SECTION  
PAGE 4-15.

### Section III Operation

Preparing Towing Vehicle.....	3-2
Preparing Implement - Lubrication.....	3-2
Preparing Implement - Tires/Wheels .....	3-2
Connecting Seed Chariot to Towing Vehicle.....	3-3
Transport Chains .....	3-3
Transporting.....	3-4
Power Pak.....	3-5
Engine Operation.....	3-6
Raising and Lowering Conveyor/Auger .....	3-7
Pivoting Conveyor or Auger Side-to-Side .....	3-7
Filling Planter or Drill .....	3-8
Loading Boxes onto Seed Chariot.....	3-9
Electronic Scale Operation - Model 640XL (Optional) .....	3-10

**Table of Contents**

**Section IV  
Maintenance**

Lubrication - Conveyor and Auger Bearings..... 4-2

Lubrication - Auger U-Joint..... 4-2

Lubrication - Pivot Points..... 4-3

Lubrication - Wheel Bearings..... 4-3

Lubrication - Engine Oil Level..... 4-3

Conveyor Belt - Belt Tension..... 4-4

Conveyor Belt - Belt Tracking..... 4-5

Conveyor Belt - Adjusting Belt Tension..... 4-5

Brake Cleaning and Inspection - Brake Lubrication..... 4-6

Brake Cleaning and Inspection - Magnets..... 4-6

Brake Cleaning and Inspection - Shoes and Linings..... 4-7

How to Measure Voltage..... 4-7

How to Measure Amperage..... 4-8

Brake Drum Inspection..... 4-9

Bearing Inspection..... 4-9

Bearing Lubrication..... 4-9

Troubleshooting Brakes..... 4-10

Battery Warranty..... 4-10

Optional Belt Stretcher..... 4-11

Stretcher Assembled to Belt..... 4-12

Wheels & Tires - Wheel Torque Requirements..... 4-13

Wheels & Tires - Tire Pressure..... 4-13

Wheels & Tires - Tire Warranty..... 4-14

Torque Chart..... 4-15

Storage..... 4-16

Troubleshooting..... 4-17

Front Undercarriage Electrical Schematic..... 4-18

Undercarriage Lighting & Brake Electrical Schematic — #25046..... 4-19

Charge From Truck Electrical Schematic — #29410..... 4-20

Conveyor or Auger Control Electrical Schematic - #28920..... 4-21

Conveyor Control Electrical Schematic - #2000588 For Electric Conveyor Lift Package..... 4-22

Switch Electrical Schematic — #26734..... 4-23

Switch Electrical Schematic — #2000617 For Electric Conveyor Lift Package..... 4-24

**Table of Contents**

**Section V  
Parts**

Decals & Touch-Up Paint.....	5-2
Stationary Bracket Components.....	5-4
Scale Components.....	5-6
Conveyor Drive Assembly & Hopper Components.....	5-8
Conveyor Idler End Components.....	5-12
Conveyor Discharge End Components.....	5-14
Auger Drive Assembly & Hopper Components.....	5-16
U-Joint, Pulley, Engine, & Battery Components.....	5-18
Auger Discharge End Components.....	5-20
Pivot Arm Components.....	5-22
Electric Conveyor Lift Package.....	5-26
Platform Components.....	5-28
Undercarriage, Hitch & Fender Components.....	5-30
Axle & Wheel Components.....	5-34
Spare Tire Kit Components.....	5-35
Telescopic Spout.....	5-36
Platform for Units Less Undercarriage Kit #2003134CG.....	5-38
AG Decal Package (Optional) - SMV, SIS Decals, & Reflectors.....	5-39

# **Section I Safety**

General Hazard Information .....	1-2
Safety Decals .....	1-3
Following Safety Instructions .....	1-4
Before Servicing.....	1-4
Before Operating.....	1-5
During Operation.....	1-5
Before Transport.....	1-6
During Transport.....	1-6
Prepare for Emergencies .....	1-7
Wearing Protective Equipment.....	1-7

## General Hazard Information

No accident-prevention program can be successful without the wholehearted cooperation of the person who is directly responsible for the operation of the equipment.

A large number of accidents can be prevented only by the operator anticipating the result before the accident is caused and doing something about it. No power-driven equipment, whether it be transportation or processing, whether it be on the highway, in the field, or in the industrial plant, can be safer than the person who is at the controls. If accidents are to be prevented--and they can be prevented--it will be done by the operators who accept the full measure of their responsibility.

It is true that the designer, the manufacturer, and the safety engineer can help; and they will help, but their combined efforts can be wiped out by a single careless act of the operator.

It is said that, "the best kind of a safety device is a careful operator." We, at Unverferth Mfg. Co., Inc. ask that you be that kind of operator.



**REMEMBER:**  
**THINK SAFETY**  
A CAREFUL OPERATOR IS THE  
BEST INSURANCE AGAINST AN  
ACCIDENT!

### SIGNAL WORDS



INDICATES AN EXTREMELY HAZARDOUS SITUATION OR ACTION THAT WILL RESULT IN SERIOUS INJURY OR DEATH.



INDICATES A HAZARDOUS SITUATION OR ACTION THAT COULD RESULT IN SERIOUS INJURY OR DEATH.



INDICATES AN UNSAFE SITUATION OR ACTION THAT MAY RESULT IN PERSONAL INJURY.



*Is used for instruction on operating, adjusting, or servicing a machine.*



Safety Decals

**⚠ WARNING**

- REPLACE LOST, DAMAGED, PAINTED, OR UNREADABLE DECALS IMMEDIATELY. IF PARTS THAT HAVE DECALS ARE REPLACED, ALSO MAKE SURE TO INSTALL NEW DECALS. THESE DECALS INFORM AND REMIND THE OPERATOR WITH OPERATIONAL INFORMATION AND SAFETY MESSAGES.

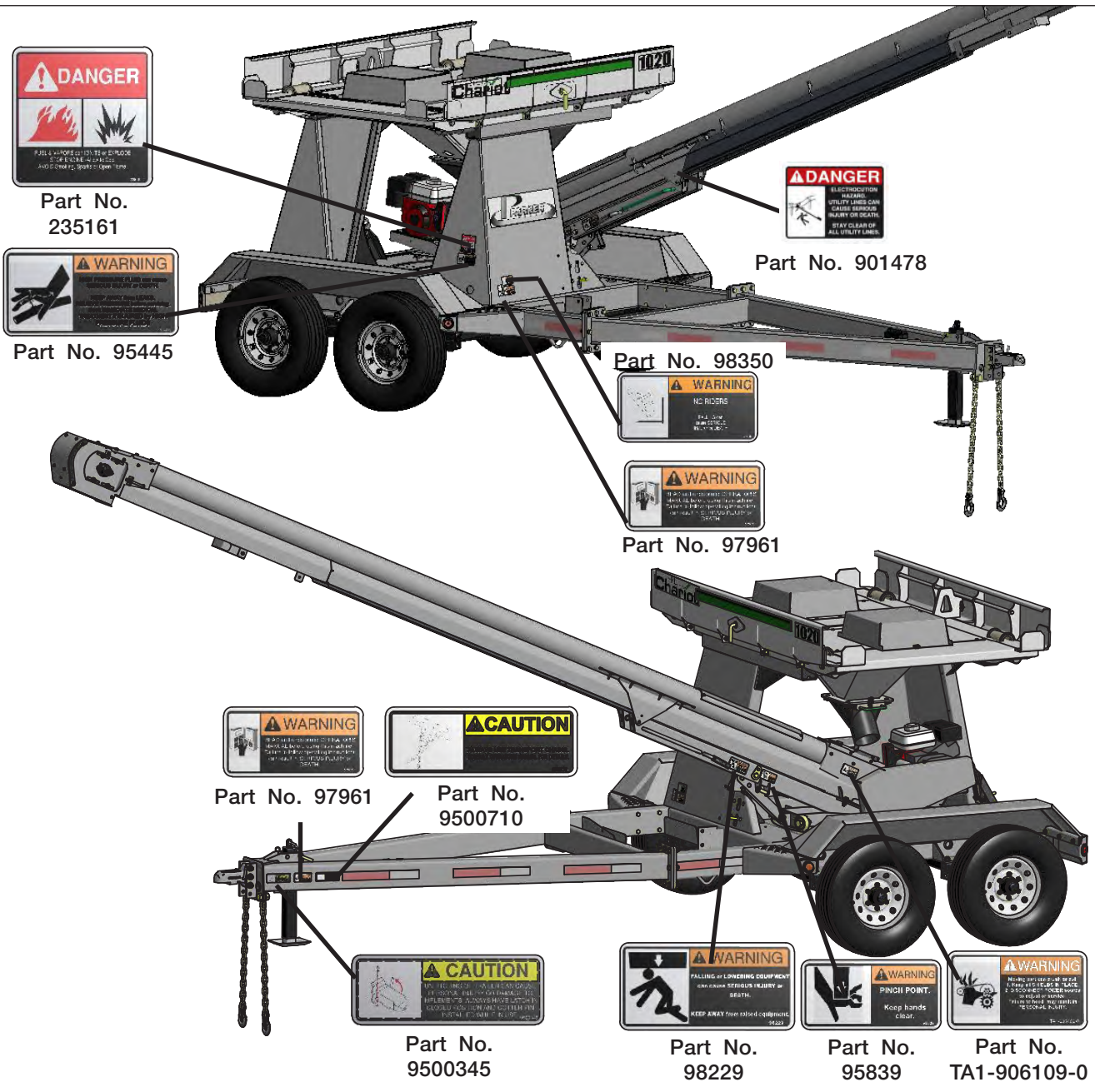

## Following Safety Instructions

- Read and understand this operator's manual before operating.



- All machinery should be operated only by trained and authorized personnel.

- To prevent machine damage, use only attachments and service parts approved by the manufacturer.

- Always shut power unit and towing vehicle engine off and remove key before servicing the Seed Chariot tender.



- Avoid personal attire such as loose fitting clothing, shoestrings, drawstrings, pants cuffs, long hair, etc., that may become entangled in moving parts.

- Never enter a Seed Tender containing grain. Flowing grain traps and suffocates victims in seconds.

- Do not allow anyone to ride on the implement. Make sure everyone is clear before operating machine or towing vehicle.



## Before Servicing

- Avoid working under the unit; however, if it becomes absolutely unavoidable, make sure the implement is safely blocked.



- Ensure that all applicable safety decals are installed and legible.

- To prevent personal injury or death, always ensure that there are people who remain outside the seed tender to assist the person working inside, and that all safe work place practices are followed. There is restricted mobility and limited exit paths when working inside the implement.

- Explosive separation of a tire and rim can cause serious injury or death. Only properly trained personnel should attempt to service a tire and wheel assembly.

### Before Operating

- Do not stand between the towing vehicle and implement during hitching.  
\_\_\_\_\_
- Always make certain everyone and everything is clear of the machine before beginning operation.  
\_\_\_\_\_
- Verify that all safety shields are in place and properly secured.  
\_\_\_\_\_
- Ensure that all applicable safety decals are installed and legible.

### During Operation

- Regulate speed to field conditions. Maintain complete control at all times.  
\_\_\_\_\_
- Never service or lubricate equipment when in operation.  
\_\_\_\_\_
- Keep away from overhead power lines. Electrical shock can cause serious injury or death.  
\_\_\_\_\_
- Use extreme care when operating close to ditches, fences, or on hillsides.  
\_\_\_\_\_
- Do not leave towing vehicle or implement unattended with engine running.  
\_\_\_\_\_
- Carbon monoxide can cause severe nausea, fainting or death. Do not operate engine in closed or confined area.  
\_\_\_\_\_
- Explosive fuel can cause fires and severe burns. Stop engine before filling fuel tank.  
\_\_\_\_\_
- Hot parts can cause severe burns. Do not touch engine while operating or just after stopping.  
\_\_\_\_\_
- Explosive gas from battery can cause fires and severe acid burns. Charge battery only in a well ventilated area. Keep sources of ignition away.  
\_\_\_\_\_
- Seed being transported may contain seed treatment. Read and follow all requirements for personal protective equipment and first aid as outlined on seed tags.

### Before Transporting

- Secure transport chains to the towing vehicle before transporting. **DO NOT** transport without chains.  
\_\_\_\_\_
- Install transport locks before transporting.  
\_\_\_\_\_
- Check for proper functioning of all available transport lights. Make sure that all reflectors are clean and in place on machine.

### During Transport

- Comply with all laws governing highway safety when moving machinery.  
\_\_\_\_\_
- Use transport lights as required by all laws to adequately warn operators of other vehicles.  
\_\_\_\_\_
- Use good judgment when transporting equipment on highways. Regulate speed to road conditions and maintain complete control.  
\_\_\_\_\_
- Maximum speed of the implement should never exceed 20 mph. Do not exceed 10 mph during off-highway travel.  
\_\_\_\_\_
- Slow down before making sharp turns to avoid tipping. Drive slowly over rough ground and side slopes.  
\_\_\_\_\_
- It is probable that this implement is taller, wider and longer than the towing vehicle. Become aware of and avoid all obstacles and hazards in the travel path of the equipment, such as power lines, ditches, etc.

## Preparing for Emergencies

- Keep a first aid kit and properly rated fire extinguisher nearby.



- Keep emergency numbers for fire, rescue, and poison control personnel near the phone.



## Wearing Protective Equipment

- Wear clothing and personal protective equipment appropriate for the job.



- Wear steel-toed shoes when operating.



- Wear hearing protection when exposed to loud noises.



- Do not wear additional hearing impairing devices such as radio headphones, etc.



**Notes**

## **Section II Set Up**

Pre-Delivery Checklist.....	2-2
Seed Chariot Assembly.....	2-3
Assemble Hitch to Undercarriage.....	2-3
Raising Conveyor/Auger to Working Position.....	2-4
Optional Scale Package (#2000621).....	2-5
Optional Electric Raise/Lower for Conveyor.....	2-7
Optional AG Decal Package, Decal Placement.....	2-8

FOR TORQUE INFORMATION, PLEASE REFER TO THE MAINTENANCE SECTION  
PAGE 4-15.

### Pre-Delivery Checklist

After the Seed Chariot tender has been completely assembled, use the following checklist and inspect the implement. Check off each item as it is found satisfactory or after proper adjustment is made.

- Torque wheel nuts as specified in Maintenance section.
- Torque all axle mounting hardware to 120 ft.-lbs.
- Tires are inflated to specified air pressure.
- All grease fittings have been lubricated.
- Check to be sure all safety decals are correctly located and legible. Replace if damaged.
- Check to be sure all reflective decals are correctly located.
- Check belt alignment and tension.
- Check to be sure transport lights are working properly.
- Transport chains are properly installed and hardware is torqued to specification.
- Paint all parts scratched in shipment.

### Seed Chariot Assembly

This section contains instructions required for assembly of the Seed Chariot tender.

For your safety, and the safety of others, use the proper tools and equipment, and always use safe working procedures. Refer to these instructions before starting any work on the machine.

#### **IMPORTANT**

- *The procedures for assembling this unit are intended for two or more people.*

For ease of assembly, install all hardware loosely until the assembly is complete and then tighten according to the Torque Chart in the Maintenance Section of this manual.

#### **⚠ WARNING**

- **READ AND UNDERSTAND SAFETY RULES BEFORE OPERATING OR SERVICING THIS MACHINE. REVIEW “SAFETY” SECTION IN THIS MANUAL IF NECESSARY.**

---

- **TIPPING OR MOVEMENT OF THE MACHINE CAN CAUSE SERIOUS INJURY OR DEATH. BE SURE THE MACHINE IS SECURELY BLOCKED.**

---

- **MOVING OR ROTATING COMPONENTS CAN CAUSE SERIOUS INJURY OR DEATH. ENSURE SERVICE COVERS, CHAIN/BELT COVERS AND CLEAN-OUT DOORS ARE IN PLACE AND SECURELY FASTENED BEFORE OPERATING THE UNIT.**

---

- **KEEP HANDS CLEAR OF PINCH POINT AREAS.**

---

- **FALLING OBJECTS CAN CAUSE SERIOUS INJURY OR DEATH. DO NOT WORK UNDER THE MACHINE AT ANY TIME WHILE BEING HOISTED. BE SURE ALL LIFTING DEVICES AND SUPPORTS ARE RATED FOR THE LOADS BEING HOISTED. THESE ASSEMBLY INSTRUCTIONS WILL REQUIRE SAFE LIFTING DEVICES UP TO 1,000 LBS. SPECIFIC LOAD RATINGS FOR INDIVIDUAL LOADS WILL BE GIVEN AT THE APPROPRIATE TIME IN THE INSTRUCTIONS.**

---

- **EYE PROTECTION AND OTHER APPROPRIATE PERSONAL PROTECTIVE EQUIPMENT MUST BE WORN WHILE SERVICING THE IMPLEMENT.**



### Assemble Hitch to Undercarriage

1. If the seed tender was shipped with a hitch installed, torque 5/8"-11UNC retaining hardware to 120-135 ft.-lbs. If it was shipped without a hitch installed, proceed to step 2.
2. Place jackstand rated for minimum 1,000 lbs. capacity under front of undercarriage frame. Raise hitch using a safe lifting device with a minimum 1,000 lbs. capacity, and place the hitch in line with the undercarriage.
3. Connect the electrical connections, and push extra wire harness into tubes. Move hitch against undercarriage frame being careful not to pinch the wiring harness.
4. Bolt the hitch to undercarriage using capscrews 5/8"-11UNC x 2 1/4" (9390-125), 5/8" stainless steel flat washers (903108), and 5/8"-11UNC locknuts (9801). Torque 5/8"-11UNC hardware to 120-135 ft.-lbs.
5. Verify the function of the seed tender lighting. See Maintenance section for the schematic, if needed.

Fig. 2-1

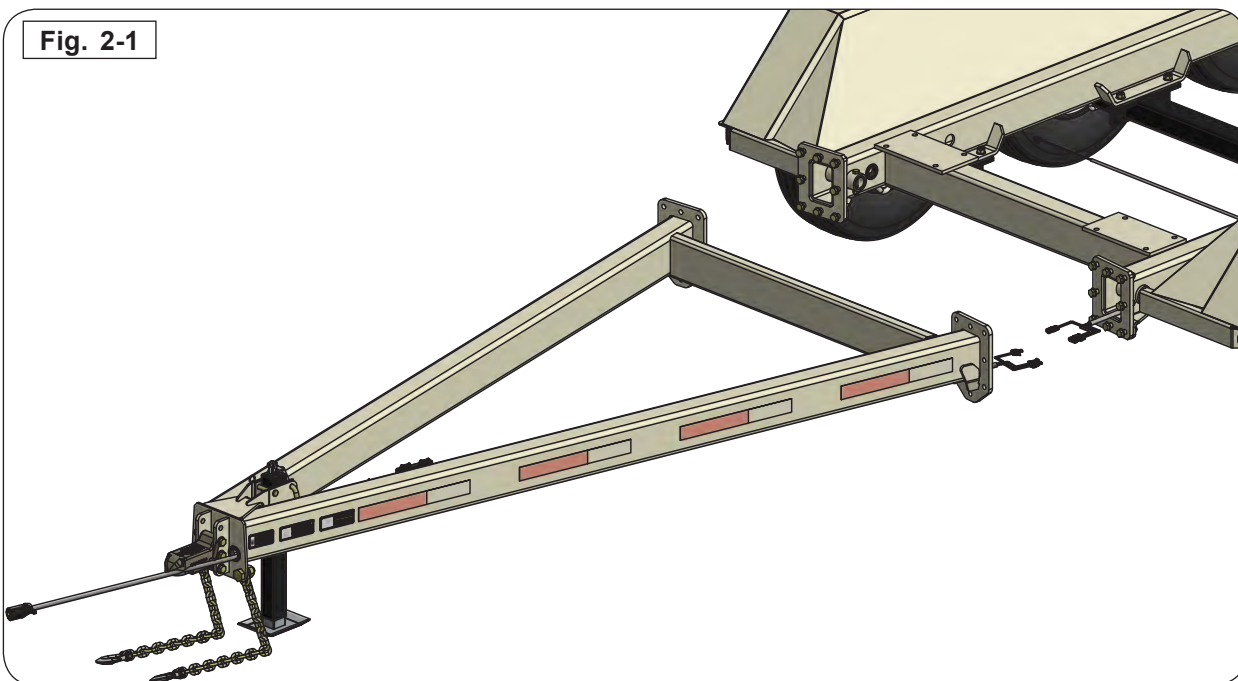

### Raising Conveyor/Auger into Working Position

Unit is shipped with the conveyor or auger in the lowered position. If the unit is not equipped with the optional electric lift/lower, it will be necessary to raise the conveyor or auger to the upper fixed position.

1. Swing the conveyor/auger out from the transport position, and latch to prevent the conveyor/auger from swinging side-to-side.
2. Remove snap ring from the 3/4" pin and remove the pin.
3. Using a safe lifting device rated for 500 lbs., lift the end of the conveyor/auger until the holes line up.
4. Install the pin and snap ring to secure in place.
5. The transport latches need to be raised.
6. Remove the 3/8" bolts and flange nuts.
7. Move the latch assembly to the raised position.
8. Repeat so that both the front and rear latches are in the raised position.
9. Slotted holes are provided in the latch assembly. Align the latch with the pin on the conveyor/auger arm so the conveyor/auger swings in place easily.
10. Tighten and torque the 3/8" bolts and flange nuts to secure the latch assemblies in place.

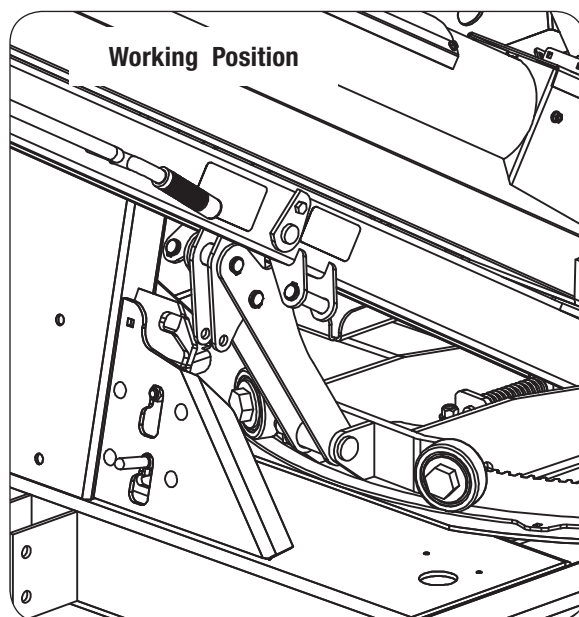
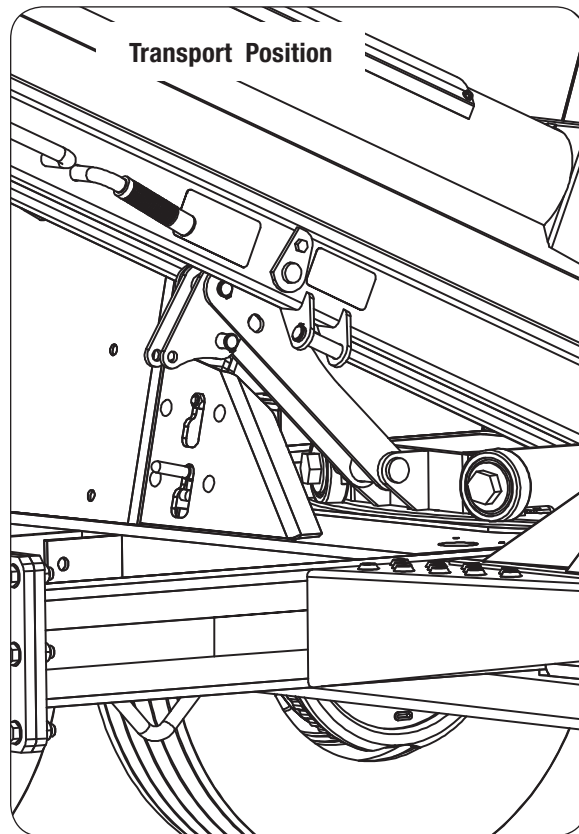

## Optional Scale Package (#2000621)

1. Assemble the weigh bars (902063) to the scale brackets using 3/8" bolts and locknuts. The weigh bars must be assembled so the 'TOP' indicator on the weigh bar is located to the bottom of the bracket or rotate the load cell so the "bending direction" decal on the end of the bar points up.
2. Using a safe lifting device rated for 1,000 lbs., support one side of the upper platform.
3. Remove the 5/8" bolts holding the stationary bracket in place.
4. Create four scale sub-assemblies by assembling the scale brackets with weigh bars (901173) making sure the 'TOP' indicator is located to the bottom of the bracket or rotate the load cell so the "bending direction" decal on the end of the bar points up, with 3/8"-16UNC x 3 1/2" capscrews (9390-065), and 3/8"-16UNC locknuts (9928).
5. Remove the stationary bracket.
6. Install the scale assemblies onto the unit in place of the stationary brackets as shown in Fig. 2. Reinstall the 5/8" bolts and locknuts, and tighten the bolts.
7. Repeat this process for all four corners.

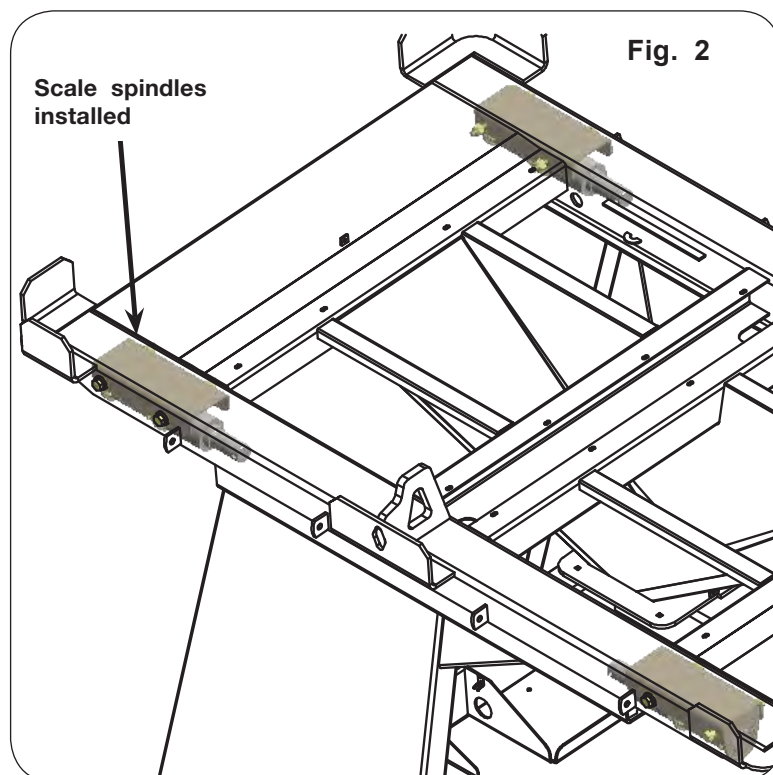
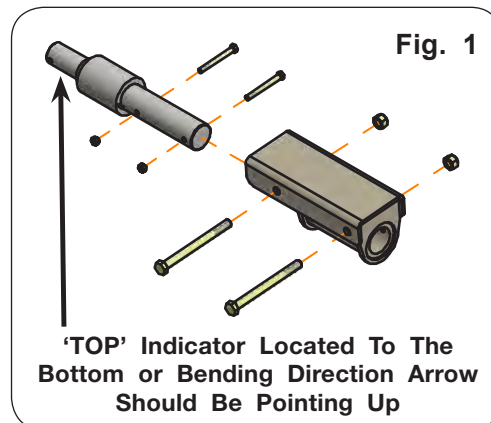

### Optional Scale Package (#2000621) (continued)

8. Remove the safe lifting device from the center plates on the upper platform.
9. Route the weigh bar cables along the inside edge of the box and fasten using the cable ties (9000106). Be certain cables will not get pinched or worn.
10. Assemble the scale enclosure to the front of the box using two 1/2"-13UNC x 1 1/2" capscrews (9390-101) and lock nuts (9800). (Fig. 3)

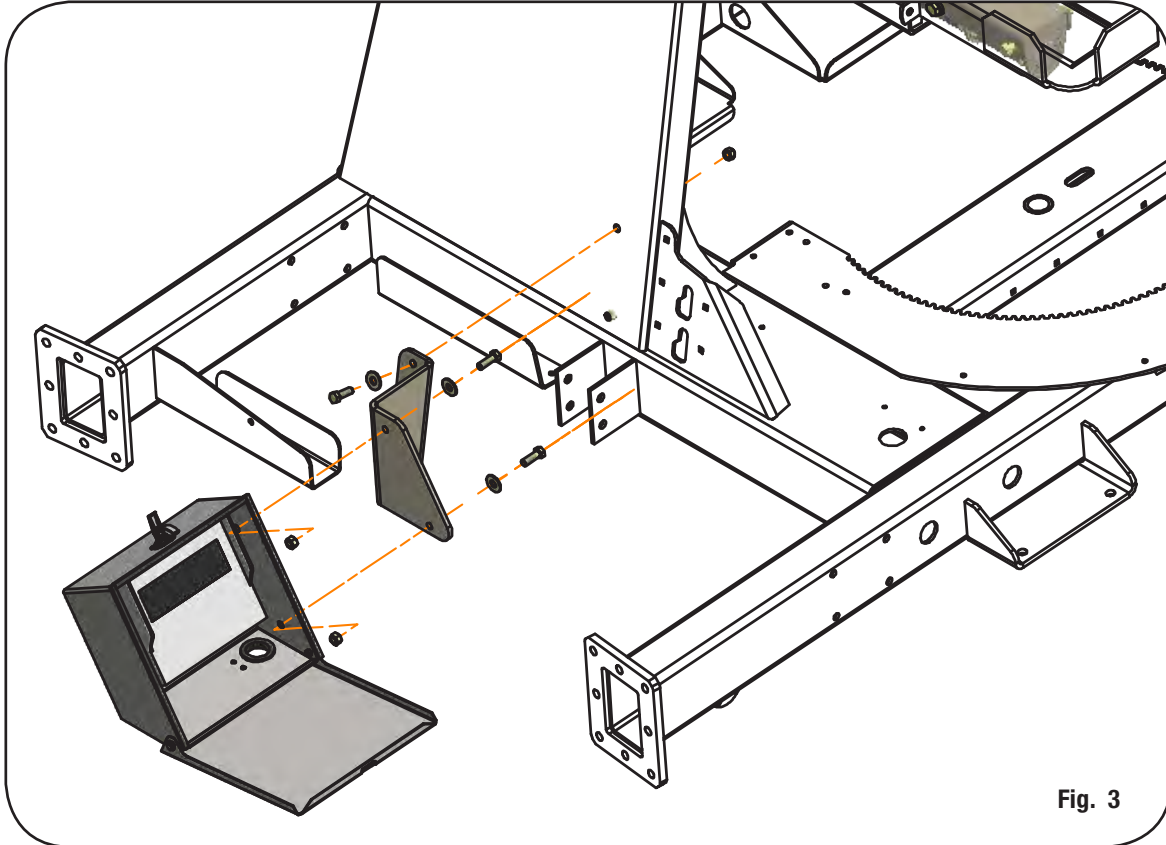
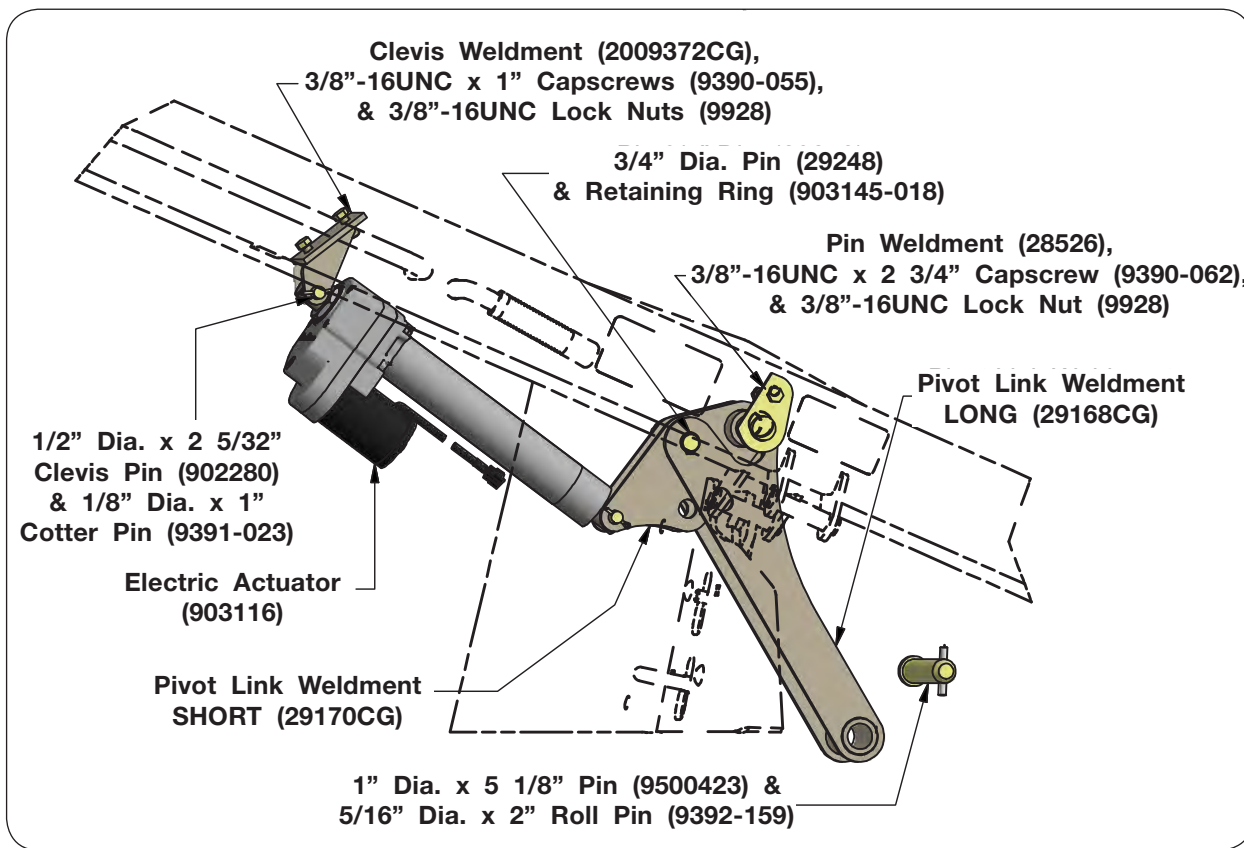

Fig. 3



## Optional Electric Raise/Lower for Conveyor/Auger

1. Attach the clevis weldment (2009372CG) to the conveyor/auger arm using 3/8" bolts and locknuts.
2. Attach the electric actuator to the support arm and lift link using the clevis pins and cotter pins. Orient the actuator as shown.
3. Replace the current wire harness with the new harness supplied in the kit.
4. Route the harness to the electric actuator and make connections.





## Optional AG Decal Package Placement

1. Center and attach the SMV Emblem (95730) to the rear of the unit 8 1/2" from the frame. (FIG. 2-20)
2. Attach the SIS decal (9008714) to the rear of the unit 13 3/4" from the bottom of the SMV Emblem (95730). (FIG. 2-20)
3. Attach the red reflector (9003126) 12 7/8" from the right-hand side of the bumper. (FIG. 2-20)

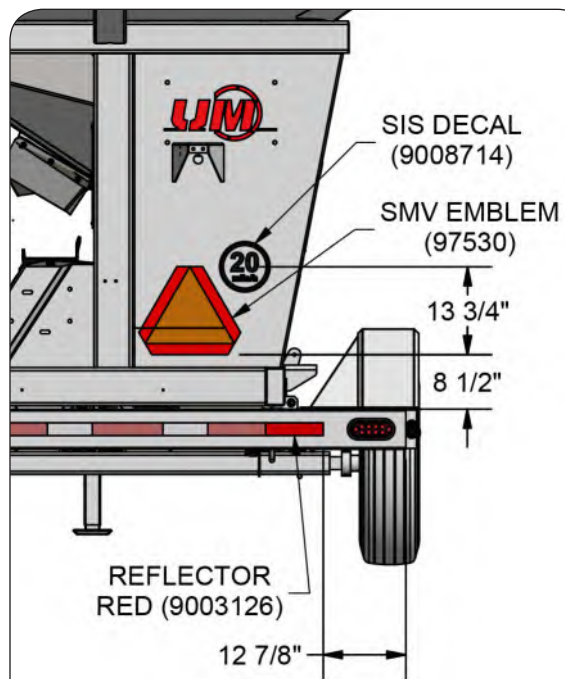

FIG. 2-20

Rear View

4. Attach the SIS decal (9008714) to the front of the unit 44 3/4" from the frame and 10 3/4" from the side of the panel as shown in FIG. 2-21.

Front View

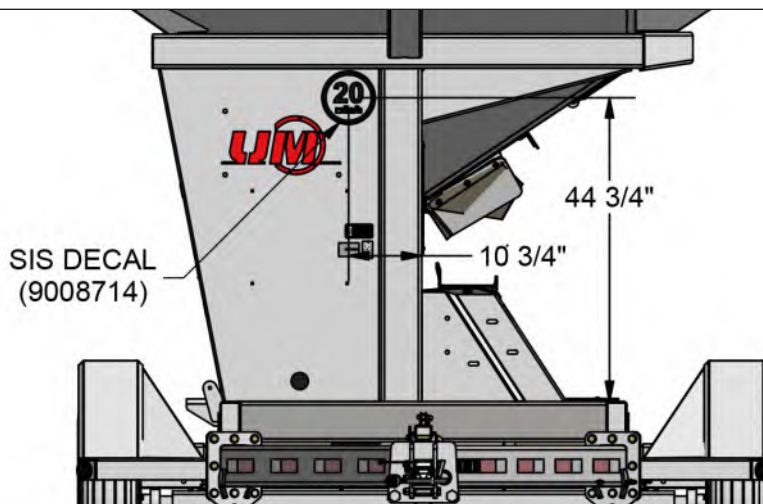
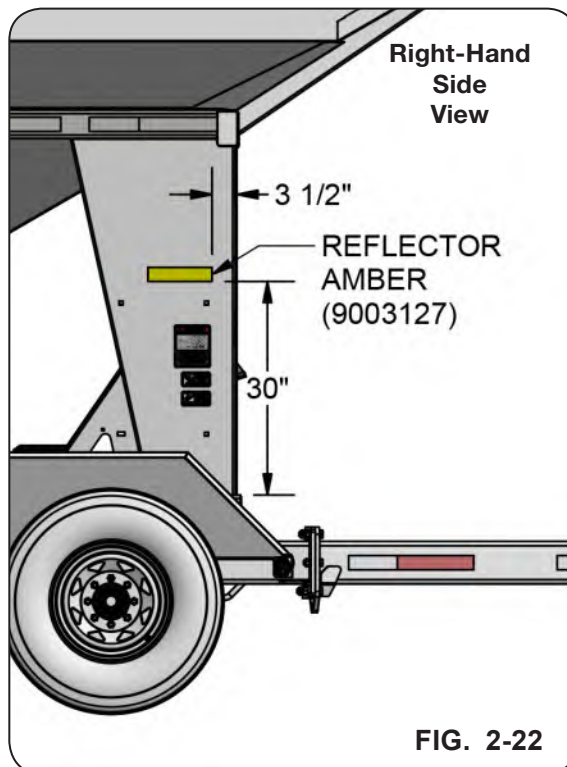

FIG. 2-21

**Optional AG Decal Package Placement (continued)**

5. Place the amber reflector (9003127) 30" from the frame and 3 1/2" from the front on the right-hand side of the unit. (FIG. 2-22)



6. Place the amber reflector (9003127) 30" from the frame and 3 1/2" from the front on the left-hand side of the unit. (FIG. 2-23)

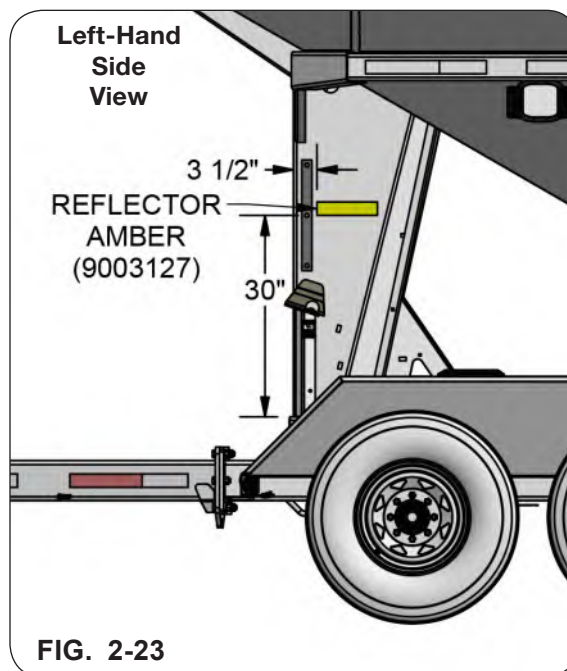

**Notes**



## **Section III Operation**

Preparing Towing Vehicle.....	3-2
Preparing Implement - Lubrication.....	3-2
Preparing Implement - Tires/Wheels .....	3-2
Connecting Seed Chariot to Towing Vehicle.....	3-3
Transport Chains .....	3-3
Transporting.....	3-4
Power Pak Warranty .....	3-5
Engine Operation.....	3-6
Raising and Lowering Conveyor/Auger .....	3-7
Pivoting Conveyor or Auger Side-to-Side .....	3-7
Filling Planter or Drill.....	3-8
Loading Boxes onto Seed Chariot.....	3-9
Electronic Scale Operation - Model 640XL (Optional) .....	3-10

### Preparing Towing Vehicle

Before operating the implement, refer to the towing vehicle's operator's manual for information concerning safe methods of operation, hitch capacities, hitch adjustments, tire inflation and undercarriage braking operation.

The vehicle must be equipped with proper electric undercarriage braking components. Check the vehicle brakes and transport lights. Make sure they are in proper working order.

Do not exceed the towing vehicle's GVWR (Gross Vehicle Weight Rating) or GCWR (Gross Combination Weight Rating), or the maximum hitch load.

Estimated weights of the fully loaded Seed Chariot tender are:

#### Model 1020

Gross Vehicle Weight Rating is 8,500 lbs.

Loaded tongue weight is 700 lbs.

These are estimates. The loaded tongue weight will vary greatly based on the height of the hitch, and the variation in the terrain that the Seed Chariot is being pulled across.

Towing vehicle hitch - ball or pintle hook, must be heavy enough to carry the load of the Seed Chariot.

### Preparing Implement

#### Lubrication

Lubricate as outlined in the Maintenance section.

Refer to this operator's manual for the proper fluid levels in the engine.

#### Tires/Wheels

Check the tire pressures and maintain at the recommended values listed in the Maintenance section of this manual.

#### CAUTION

- **IMPROPERLY TORQUED WHEEL NUTS/BOLTS CAN CAUSE A LOSS OF IMPLEMENT CONTROL AND MACHINE DAMAGE. WHEEL NUTS/BOLTS MUST BE CHECKED REGULARLY. SEE THE TORQUE PAGE IN THE MAINTENANCE SECTION FOR PROPER WHEEL NUT/BOLT SPECIFICATIONS. WARRANTY DOES NOT COVER FAILURES CAUSED BY IMPROPERLY TORQUED WHEEL NUTS/BOLTS.**

For questions regarding new tire warranty, please contact your local original equipment tire dealer. Used tires carry no warranty. Tire manufacturers' phone numbers and web sites are listed in the Maintenance section of this manual for your convenience.

### Connecting Seed Chariot to Towing Vehicle

#### **⚠ WARNING**

- **DO NOT STAND BETWEEN THE IMPLEMENT AND THE TOWING VEHICLE WHEN HITCHING.**

The Seed Chariot undercarriage is designed to be connected to a towing vehicle utilizing either the pintle hitch, or a 2 5/16" ball hitch.

Back the towing vehicle up to the undercarriage and align the vehicle's ball or pintle hook with the coupler or ring on the undercarriage. Lower the jack to set the undercarriage down on the ball or pintle hook. Latch the coupler so the connection is secure. Pivot the jack to the transport position and pin in place.

Connect the electrical plug from the undercarriage to the towing vehicle. Check the routing of the electrical cord to be certain it is long enough to pivot when turning, but not too long to touch or rub the ground during transport.

Connect the undercarriage brake breakaway cable to the towing vehicle. Do not connect this directly to the hitch. It needs to be connected in a place that will still be attached, even if the ball or pintle coupler fails.

### Transport Chains

#### **⚠ CAUTION**

- **ALWAYS USE THE TRANSPORT CHAINS WHEN TRANSPORTING THE IMPLEMENT. FAILURE TO USE THE CHAINS COULD CAUSE PERSONAL INJURY OR DAMAGE IF THE IMPLEMENT BECOMES DISENGAGED.**

Transport chains should have a minimum rating equal to the gross weight of the implement and all attachments. Allow no more slack in the chains than necessary to permit turning.

Cross the chains when connecting as shown in the photo to the right.

#### **IMPORTANT**

- *Replace the transport chains if any link or end fitting is broken, stretched or damaged. DO NOT WELD TRANSPORT CHAINS.*



## Transporting

### DANGER

- CONTACT WITH UTILITY LINES CAN CAUSE SERIOUS INJURY OR DEATH. DO NOT OPERATE THE SEED CHARIOT NEAR UTILITY LINES.



### WARNING

- ALWAYS TRAVEL AT A SPEED THAT PERMITS COMPLETE CONTROL OF THE TOWING VEHICLE AND IMPLEMENT.
- USE TRANSPORT LIGHTS AS REQUIRED BY ALL LAWS TO ADEQUATELY WARN OPERATORS OF OTHER VEHICLES.

### IMPORTANT

- Before the unit is transported, be sure the jack stand is in the 'Transport Position'.

When transporting on public roads, the conveyor/auger needs to be latched in the forward position, extending over the tongue of the undercarriage. Transporting the implement with the conveyor/auger latched in the rearward position does not comply with lighting and conspicuity marking requirements.

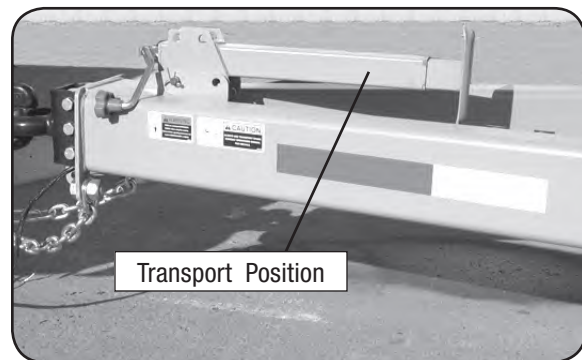

The center of gravity on the Seed Chariot box carrier is higher than a typical undercarriage. Use extreme caution when making turns and entering/exiting fields.

Comply with all laws governing highway safety and regulation when moving machinery on public roads.

Be sure the reflectors and lights are in place and clearly visible to approaching traffic.

Be certain clearance to rafters, walls, machinery, etc. exists before operating the conveyor/auger. With a towing vehicle hooked to the Seed Chariot tender, activate the belt to make sure everything moves freely.

## **Power Pak Warranty**

For general maintenance and servicing of power pak unit.

**NOTE:** For maintenance of engine and warranty information, refer to Operator's Manual provided with engine. Following are phone numbers and Websites for your convenience:

**US**      [www.honda-engines.com](http://www.honda-engines.com)  
Phone 800-426-7701

**Canada**      [www.honda.ca](http://www.honda.ca)  
Phone 888-9HONDA9

Please provide Honda with the following engine information:  
4.8 HP GX160 UT2RXE2

## Engine Operation

### **WARNING**

- **EXPLOSIVE FUEL CAN CAUSE FIRES AND SEVERE BURNS. STOP THE ENGINE BEFORE FILLING THE FUEL TANK.**

---

- **CARBON MONOXIDE CAN CAUSE SEVERE NAUSEA, FAINTING OR DEATH. DO NOT OPERATE THE ENGINE IN A CLOSED OR CONFINED AREA.**

---

- **HOT PARTS CAN CAUSE SEVERE BURNS. DO NOT TOUCH THE ENGINE WHILE OPERATING OR JUST AFTER STOPPING.**

---

- **EXPLOSIVE GASES FROM THE BATTERY CAN CAUSE FIRES AND SEVERE ACID BURNS. CHARGE THE BATTERY ONLY IN A WELL VENTILATED AREA. KEEP SOURCES OF IGNITION AWAY.**

---

- **OPERATION OF THIS EQUIPMENT MAY CREATE SPARKS THAT CAN START FIRES AROUND DRY VEGETATION. A SPARK ARRESTOR MAY BE REQUIRED. THE OPERATOR SHOULD CONTACT LOCAL FIRE AGENCIES FOR LAWS OR REGULATIONS RELATING TO FIRE PREVENTION REQUIREMENTS. THE SPARK ARRESTOR MUST BE PURCHASED SEPARATELY AND CAN BE FOUND IN THE PARTS SECTION NEAR THE END OF THIS MANUAL.**

### **IMPORTANT**

- *When the engine is not in use, turn the fuel lever to the <OFF> position. Leaving the fuel valve on could cause carburetor flooding, fuel in the crankcase or fuel leakage. See photos to the right.*

**NOTE:** Installation instructions for the spark arrestor can be found in the Honda engine manual.

#### Starting Engine:

Turn the fuel shut-off valve to the <ON> position. Apply the choke, and turn the key or pull recoil rope to start the engine. Once the engine is running, turn the choke off and increase the throttle speed.

In extremely cold weather, it is best to allow the engine to warm up before operating at full throttle speed.

See the engine operator's manual for more detailed information on engine operation.

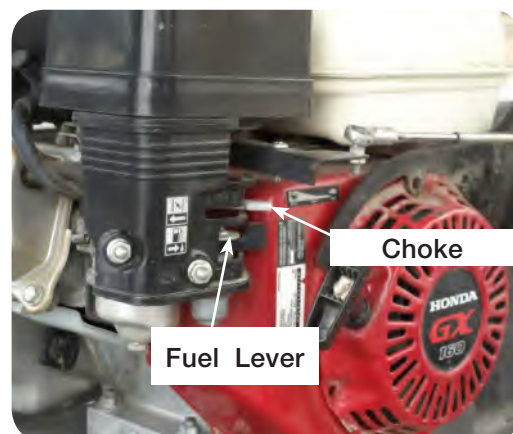
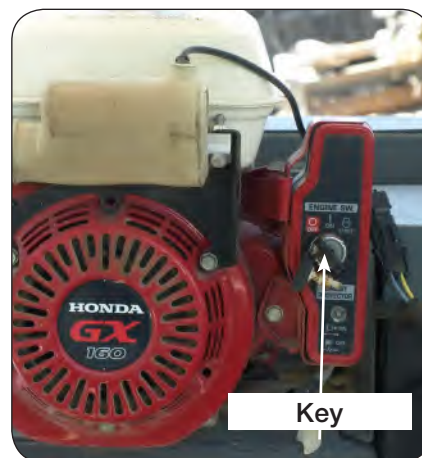

### Raising and Lowering Conveyor or Auger

If equipped with electric lift/lower, the conveyor/auger can be raised by first pivoting the conveyor/auger out of the transport position, and then actuating the raise/lower button on the wired switch.



### Pivoting Conveyor or Auger Side-to-Side

Unlatch the locking arm by pressing down and sliding the latch into the unlocked position. Turn the pivot latch handle down and pull the conveyor/auger out away from the box to pivot.

#### IMPORTANT

- Do not raise the conveyor/auger arm until it has been moved out of the latch position.

Conveyor/auger pivot can be left to swing freely, or it can be latched in place at various points along the track.

#### CAUTION

- WHEN THE SEED CHARIOT TENDER IS PARKED ON AN INCLINE, THE CONVEYOR/AUGER MAY PIVOT AS SOON AS THE LATCH IS RELEASED. INADVERTANT MOVEMENT OF THE CONVEYOR/AUGER MAY CAUSE PERSONAL INJURY.





### Filling Planter or Drill

The conveyor/auger On/Off is controlled by a centrifugal clutch on the engine. Increasing the engine speed will engage the clutch and turn the conveyor/auger on. Continuing to increase the engine speed will increase the belt speed. Decreasing the engine speed will slow the belt, and eventually disengage the clutch to turn the conveyor/auger off. Engine speed is controlled by a button on the hand-held controller.

Position the Seed Chariot tender next to the planter so the conveyor/auger discharge will be over the planter box. Raise the conveyor/auger to the desired discharge height, and pivot to the location over the planter. Place the telescoping spout over the planter box. Start the engine and open the flow door(s) on the Seed Chariot to begin the flow of seed. Increase the engine throttle speed to start the conveyor/auger.

Fill the box to the desired level, and turn the conveyor/auger off by decreasing the throttle speed. Repeat the process until each box/hopper is filled. Adjusting the engine speed regulates the conveyor/auger speed.



### IMPORTANT

- Do not let the telescoping spout rest in the bottom of the seed box. Seed will rapidly build up and plug the conveyor, resulting in potential damage to the belt.

It is recommended that the conveyor/auger be emptied once the planter is filled. Do this by closing the door(s) on the Seed Chariot box shortly before the last planter box is full, and let the conveyor/auger empty out.

Leaving seed in the conveyor/auger for short periods of time will not damage the conveyor/auger, nor will it hinder starting/stopping the conveyor/auger when it is full, but over time, seed could begin to settle resulting in hard starting of the conveyor/auger.



## Loading Boxes Onto Seed Chariot

1. Remove covers from the Seed Chariot box chute by removing the pin holding the cover in place. Place the pin back into the bracket.

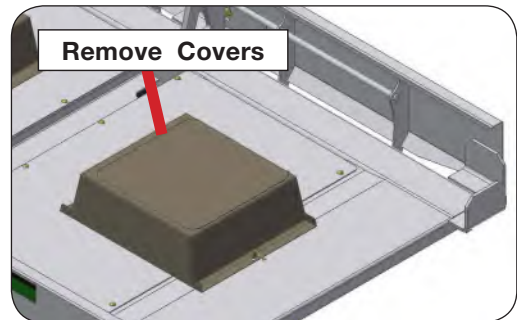

2. Locate covers in storage position in front of the front standard, securing with provided bungee cord.



3. Remove the pin on the box hold downs to unlock.

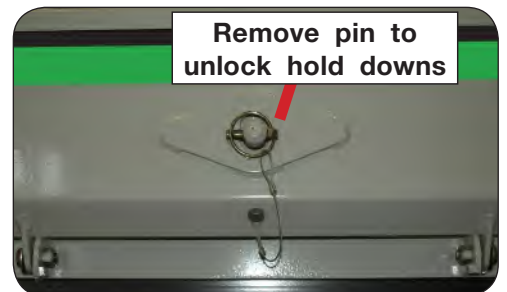

4. Lift boxes into position on platform.

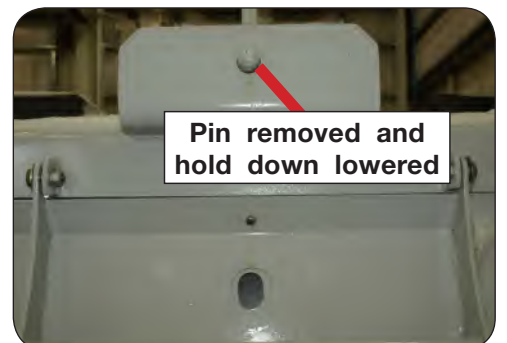

5. With boxes in position, push all box hold downs into position and replace the pin to lock into place.

## Electronic Scale Operation - Model 640XL (Optional)

The following instructions can also be found in your scale/indicator user's manual.

### Key Functions

#### ON/OFF

Pressed to power on or off the indicator.

#### RM

Pressed to access memory channel. Also used to increment numbers during the numeric entry procedure.

#### M+

Pressed to accumulate weights. Also used to decrement numbers during the numeric entry procedure.

#### TARE

Pressed to tare the weight on the scale.

#### G/N

Pressed to toggle between gross and net weight.

#### HOLD/MENU

Press and hold to display weight. Press again to release the hold mode. Also used to move to the right in the menu structure and to move the numeric entry cursor one space to the right.

#### PRINT/SELECT

Press to send data to an attached data collection device, printer, TDM or computer. Also used to move down in the menu structure.

#### ZERO/CLEAR

Press to zero G/N weight. Also used to clear memory channels.



### Zeroing & Weighing

1. Press ON  
Display shows HELLO, then the current weight value is displayed.
2. Press G/N and access gross mode...  
Live scale weight is displayed in the G/N weighing mode.
3. Remove all material from the scale and press ZERO/CLEAR  
0 is displayed, and the system is zeroed.

### Gross/Tare/Net Weighing

1. After zeroing and weighing, place the material to be tared on the scale...  
Weight of the material is displayed
2. Press the TARE key to tare the weight from the display...  
0 weight is displayed and the NET annunciator lights to indicate there is an active tare weight.
3. Place the material to be weighed on the scale...  
Net weight is displayed.

### Electronic Scale Operation - Model 640XL (Optional) (continued)

#### Gross/Tare/Net Weighing (continued)

4. Remove the weighed material from the scale (leaving the tared item).
5. Repeat steps 2 through 5 for each weighing using the same tare weight.
6. To remove the tare weight, press the G/N key to return to gross weigh mode, then press the ZERO/CLEAR key...

The tare weight is removed and you can repeat this process to weigh more material with a different tare.

#### Print All Memory Channels

1. Press RM^...  
Latest memory channel is displayed.
2. Press PRINT/SELECT for 2 beeps (2 secs)  
PR-ALL is momentarily displayed and information is transmitted.
3. Indicator returns to gross weighing mode.

The indicator will only print out memory channels that have accumulated weight amounts.

#### How to Configure Filtering

If you need to adjust the filtering on your Model 640 to counteract excessive movement or vibration on the scale system, follow these steps to access the FILTER menu item of the Setup menu and make needed changes.

1. Access the Setup menu from the G/N mode. To do so, press and hold the HOLD/MENU key for three beeps (3 seconds), then release...  
SET.PAS is displayed
2. Use the numeric entry procedure to enter the password 640. Press PRINT/SELECT to accept it...  
640 is shown
3. Press PRINT/SELECT once more...  
CONFIG is displayed.
4. Repeatedly press the HOLD/MENU key until...  
FILTER is displayed. There are two parts to filtering; Constant and Window. How to set these is explained on the next page.

## Electronic Scale Operation - Model 640XL (Optional) (continued)

### How to Configure Filtering (continued)

5. Press the PRINT/SELECT key twice...  
The current CONSTANT value is shown. Press the HOLD/MENU key to increase the value. Increasing this value causes the indicator to ignore increasing amounts of weight change on the scale. This means small changes can be ignored at a relatively small CONSTANT value. To filter larger changes out, choose a larger CONSTANT value. (Choices are OFF to 10, Default=2)
6. When the value you want to try is displayed, press the PRINT/SELECT key...  
Your choice is selected and CONST is displayed.
7. Press the HOLD/MENU key...  
WINDOW is displayed. This is where you will set the threshold window of the filter parameter. You can enter 0 to full capacity.
8. Press the PRINT/SELECT key...  
Current setting for the threshold window is displayed.
9. Use the numeric entry procedure to enter a new value. Press the PRINT/SELECT key to accept it...  
WINDOW is displayed.
10. Repeatedly press the G/N key until you return to the gross weighing mode.  
Check the function of the indicator. If the weight display does not act in a manner to your liking, repeat steps 1 through 9 until the indicator functions as desired.

### Display Messages

The following are the messages that may appear on the display and what they mean:

Message	Meaning
HELLO	Message displayed on power-up sequence for 3 seconds.
-----	UPPER DASHES, Indicator is in a state of overcapacity, or analog input is too high.
-----	LOWER DASHES, Indicator is in a state of under capacity, or analog input is too low.
NO TARE	Displayed when you press the G/N key and there is no tare weight established.
PRINT	Indicator is transmitting data. Appears after pressing the print key for a second.
LO-BAT	Alternates on the display between current mode and LOBAT when input voltage is between 9-10 volts.
HOLD	Used when moving a portable system.
L XXX	XXXX = weigh value Displayed when the indicator is in AUTO-LOC mode and has locked on a weight.

## Electronic Scale Operation - Model 640XL (Optional) (continued)

### Display Messages (continued)

The following are the messages that may appear on the display and what they mean:

Message	Meaning
+RANGE	Displayed when the weight input exceeds 8 mV/V.
-RANGE	Displayed when the weight input exceeds -8 mV/V.
SHTDWN	Shown on the display prior to shutting the indicator off after the sleep timer has expired, or when you press the ON/OFF key. (10 seconds before the sleep timer shuts down, the alarm will beep several times).
CAN'T	Displayed when attempting to access too large of a numeral.

### Editing the A-List

#### Menu Navigation



Moves right in the menu structure.



Moves up in the menu structure.



Selects displayed option and moves up/down in menu structure at 

If the application requires alphanumeric channel names, go through the memory channel list, and edit their descriptions accordingly. Example, if you want to record Seed Chariot loads from five different fields, then create a list of FIELD1, FIELD2, ...FIELD3. Now the custom names of the memory channels can be used, otherwise all memory channels will be the default descriptions of MEM.001, MEM.002, etc.

1. From the G/N mode, press HOLD/MENU for 2 beeps...  
A-LIST is shown on the display
2. Press the PRINT/SELECT key...  
EDIT is displayed
3. Press PRINT/SELECT again and...  
MEM.001 is displayed, or the last memory channel accessed.

If reviewing the memory channel list, to edit, get to the displayed channel by pressing and holding on the HOLD/MENU key, or use the RM^ key in conjunction with the HOLD/MENU key to go directly to a memory channel to edit its name. Example: Press PM^ three times to reach 2, and then press PRINT/SELECT and MEM.002 will be displayed on the screen.

4. Press G/N three times to return to G/N weighing mode.

**Notes**

## **Section IV Maintenance**

Lubrication - Conveyor and Auger Bearings.....	4-2
Lubrication - Auger U-Joint.....	4-2
Lubrication - Pivot Points.....	4-3
Lubrication - Wheel Bearings.....	4-3
Lubrication - Engine Oil Level.....	4-3
Conveyor Belt - Belt Tension.....	4-4
Conveyor Belt - Belt Tracking.....	4-5
Conveyor Belt - Adjusting Belt Tension.....	4-5
Brake Cleaning and Inspection - Brake Lubrication.....	4-6
Brake Cleaning and Inspection - Magnets.....	4-6
Brake Cleaning and Inspection - Shoes and Linings.....	4-7
How to Measure Voltage.....	4-7
How to Measure Amperage.....	4-8
Brake Drum Inspection.....	4-9
Bearing Inspection.....	4-9
Bearing Lubrication.....	4-9
Troubleshooting Brakes.....	4-10
Battery Warranty.....	4-10
Optional Belt Stretcher.....	4-11
Stretcher Assembled to Belt.....	4-12
Wheels & Tires - Wheel Torque Requirements.....	4-13
Wheels & Tires - Tire Pressure.....	4-13
Wheels & Tires - Tire Warranty.....	4-14
Torque Chart.....	4-15
Storage.....	4-16
Troubleshooting.....	4-17
Front Undercarriage Electrical Schematic.....	4-18
Undercarriage Lighting & Brake Electrical Schematic — #25046.....	4-19
Charge From Truck Electrical Schematic — #29410.....	4-20
Conveyor or Auger Control Electrical Schematic - #28920.....	4-21
Conveyor Control Electrical Schematic - #2000588 For Electric Conveyor Lift Package.....	4-22
Switch Electrical Schematic — #26734.....	4-23
Switch Electrical Schematic — #2000617 For Electric Conveyor Lift Package.....	4-24

## Lubrication

Lubricate with an SAE multi-purpose grease. All fittings must be free from dirt and paint to insure entry of lubricant inside the bearing.

### Conveyor and Auger Bearings

Lubricate these bearings every 100 hours of operation and at the end of each season before storage. Use only one stroke of grease per bearing.

#### **IMPORTANT**

- DO NOT USE A HIGH-PRESSURE GREASE GUN TO LUBRICATE THE CONVEYOR/AUGER BEARINGS, AS DAMAGE TO THE BEARING SEAL COULD OCCUR.

**NOTE:** Excessive lubrication of these bearings will result in premature failure.

### Auger U-Joint

#### **WARNING**

- MOVING OR ROTATING COMPONENTS CAN CAUSE SERIOUS INJURY OR DEATH ENSURE SERVICE COVERS, CHAIN/BELT COVERS AND CLEAN-OUT DOOR ARE IN PLACE AND SECURELY FASTENED BEFORE OPERATING UNIT.

Lubricate the U-joint every 50 hours of operation and at the end of each season before storage.

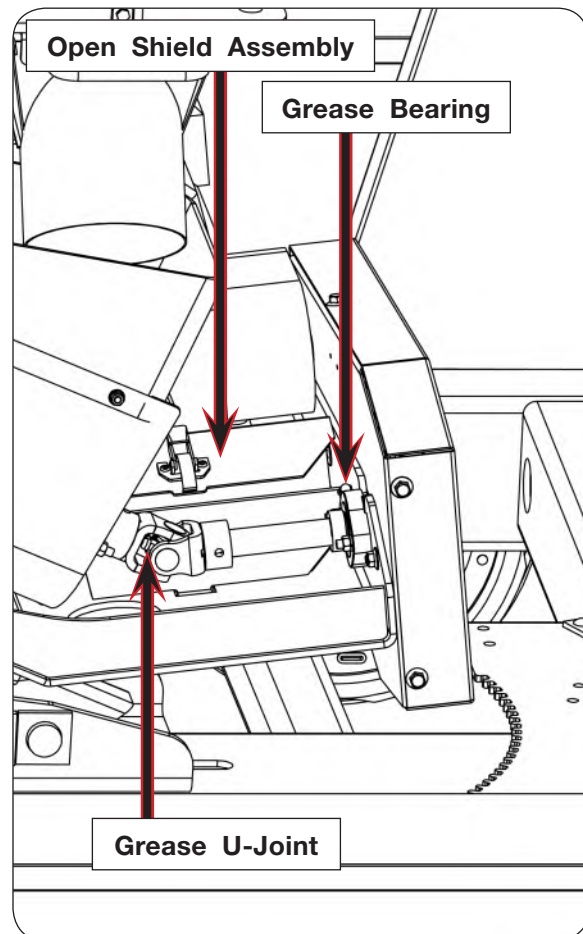



## Lubrication (continued)

### Pivot Points

Lubricate the pivot points on the pivoting arm every 50 hours of operation and at the end of each season.

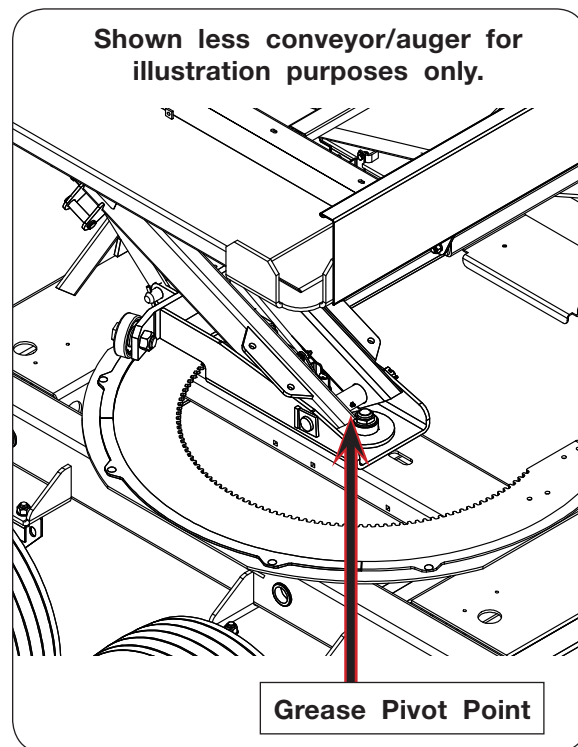

### Wheel Bearings

The wheel bearings should be cleaned, repacked and adjusted every 12 months or 12,000 miles, whichever comes first. Use a number 2 wheel bearing grease to repack the bearings and adjust the bearing to a free-rolling fit with no end play.

### Engine Oil Level

Check the motor oil level in the engine daily. See the Engine operator's manual for details on oil levels, oil types and service intervals.

## Conveyor Belt

Proper belt tension and correct 'tracking' of the belt are critical to maintaining the belt for years of worry-free use. Belt tension and tracking should be checked at the beginning of each season. Belt alignment should be checked after the very first initial use then after the first 2 hours of initial use or after every adjustment of the belt tension/alignment. Once the belt tracking is set, it will be necessary to check the alignment after every 8 hours of use.

### **WARNING**

- **MOVING OR ROTATING COMPONENTS CAN CAUSE SERIOUS INJURY OR DEATH. USE EXTREME CARE WHEN INSPECTING AND ADJUSTING BELT TRACKING.**

## Belt Tension

Belt tension is inspected by removing the lower cover panel from the conveyor, and gently pulling on the conveyor belt. The belt should have approximately 1 1/2" - 2" of slack at the center.

Belt tension is adjusted at the discharge end of the conveyor. Loosen, **DO NOT REMOVE**, the four 3/8" bolts on each side of the conveyor. Use the two adjusting bolts to adjust the belt to the proper tension.

It is important to move both sides the same distance. Too much tension on the belt will stretch the splice link and greatly reduce belt life. Too little tension on the belt could result in belt slipping on the drive pulley. Replace the bottom cover panel and continue to check the belt tracking before re-tightening the four bolts on each side of the conveyor.

### **IMPORTANT**

- *Belt tracking must be done every time tension is adjusted.*

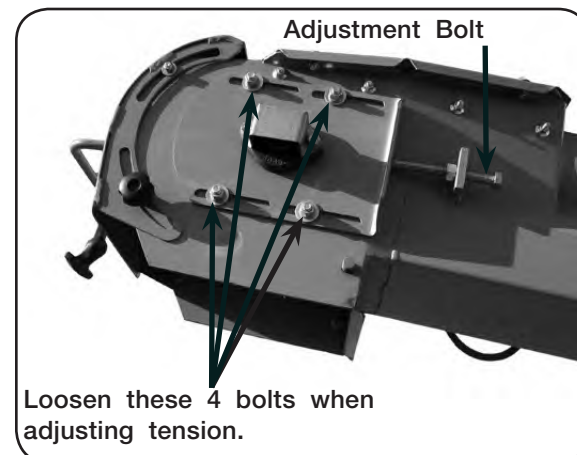
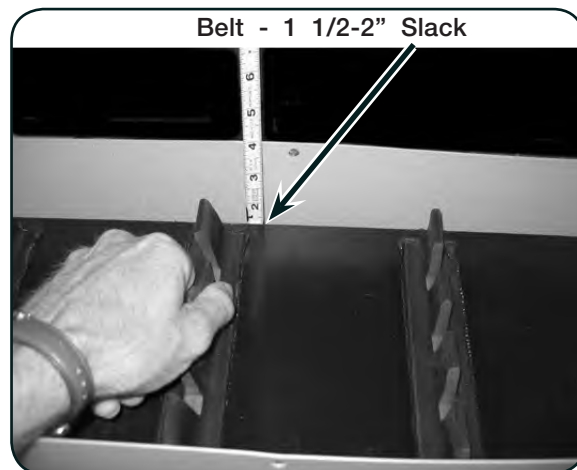

## Conveyor Belt (continued)

### Belt Tracking

The conveyor belt must always run at the center of the pulley in both the intake and discharge end. Improper tracking of the belt will result in excessive wear to the edge of the belt, and will greatly reduce belt lift. Check the belt tracking every 8 hours of use, and every time belt tension is adjusted.

Inspect the tracking of the belt at the discharge end by removing the lower spout, pivoting the deflector up and looking up at the belt and pulley. The belt should be in the center of the pulley.

Adjust by loosening, **DO NOT REMOVE**, the four bolts on the side of the conveyor. Operate the conveyor at a slow speed, and tighten or loosen the adjustment bolt until the belt is running in the center of the pulley.

Tighten all bolts on the side of the conveyor, and lock the adjustment bolts into place.

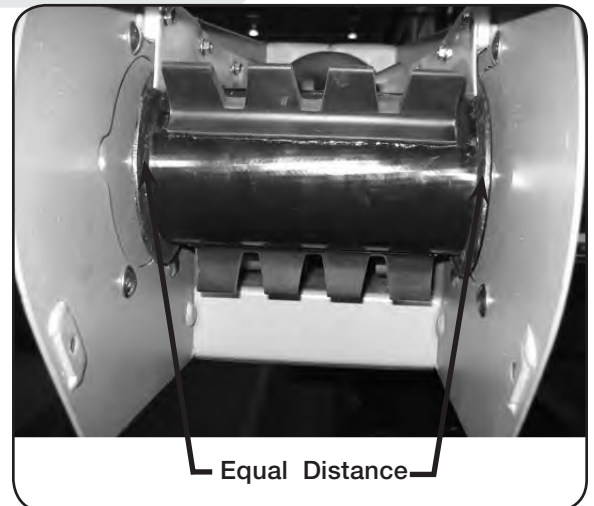

### Adjusting Belt Tension

1. With the engine turned off, and key removed, remove the belt shield by removing the 5/16" bolts to access the drive belt.
2. Loosen the engine by loosening (do not remove) four carriage bolts.
3. Loosen the lock nut on the adjustment bolt and tighten the belt by turning the adjustment bolt.
4. Once the tension is set, tighten the bolts on the engine plate, and re-inspect the tension.
5. Lock the adjustment bolt in place with the lock nut.
6. Re-install the shield.

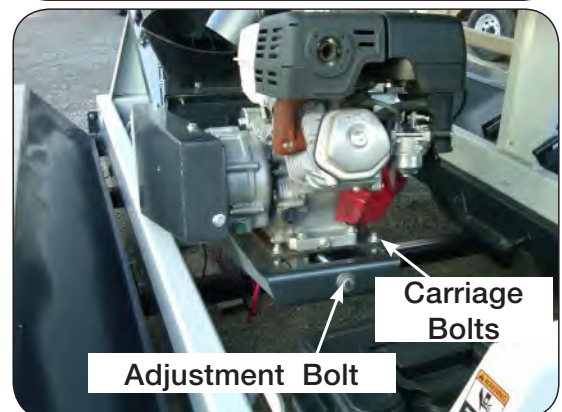
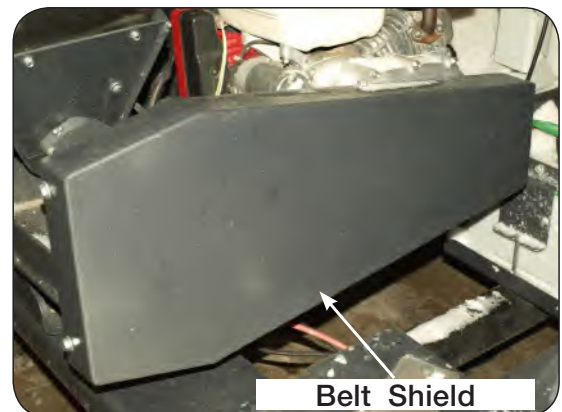

### Brake Cleaning and Inspection

Your undercarriage brakes must be inspected and serviced immediately if a loss of performance is experienced. With normal use, servicing at one year intervals is usually adequate. With increased usage, this work should be performed more frequently as required. Magnets and shoes must be changed when they become excessively worn or scored, a condition which can reduce vehicle braking. Clean the backing plate, magnet arm, magnet, and brake shoes. Make certain that all the parts removed are replaced in the same brake and drum assembly. Inspect for any loose or worn parts, stretched or deformed springs and replace as necessary.

### **⚠ WARNING**

- **POTENTIAL ASBESTOS DUST HAZARD - SOME BRAKE LININGS MAY CONTAIN ASBESTOS DUST, WHICH HAS BEEN LINKED TO SERIOUS OR FATAL ILLNESSES. CERTAIN PRECAUTIONS NEED TO BE TAKEN WHEN SERVICING BRAKES:**

1. Avoid creating or breathing dust.
2. Avoid machining, filing or grinding the brake linings.
3. Do not use compressed air or dry brushing for cleaning (dust can be removed with a damp brush).

### Brake Lubrication

Before reassembling, apply a light film of grease or anti-seize compound on the brake anchor pin, the actuating arm bushing and pin, and the areas on the backing plate that are in contact with the brake shoes and magnet lever arm. Apply a light film of grease on the actuating block mounted on the actuating arm.

**NOTE:** Do not get grease or oil on the brake linings, drums or magnets.

### Magnets

Your electric brakes are equipped with high quality electromagnets that are designed to provide the proper input force and friction characteristics. Your magnets should be inspected and replaced if worn unevenly or abnormally. Use a straightedge to check magnet condition. For best results, the magnet should be flat. Even if wear is normal as indicated by your straightedge, the magnets should be replaced if any part of the magnet coil has become visible through the friction material facing of the magnet. It is also recommended that the drum armature surface be refaced when replacing magnets. Magnets should also be replaced in pairs - both sides of an axle.

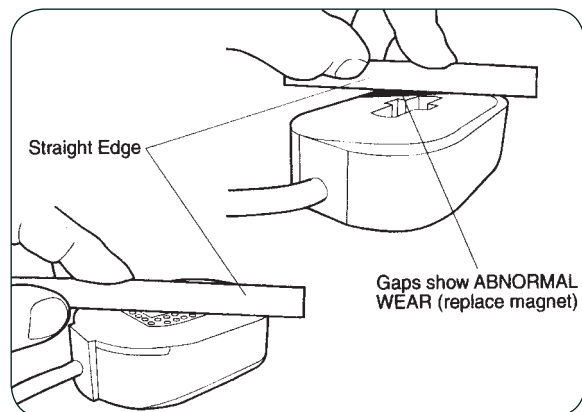

### Brake Cleaning and Inspection (continued)

#### Shoes and Linings

A simple visual inspection of your brake linings will tell if they are usable. Replacement is necessary if the lining is worn (to within 1/16" or less), contaminated with grease or oil, or abnormally scored or gouged. Hairline heat cracks are normal in bonded linings and should not be cause for concern. When replacement is necessary, it is important to replace both shoes on each brake and both brakes of the same axle. This will help retain the "balance" of your brakes.

After replacement of the brake shoes and linings, the brakes must be re-burnished to seat in the new components. This should be done by applying the brakes 20 to 30 times from an initial speed of 40 m.p.h., slowing the vehicle to 20 m.p.h. Allow ample time for brakes to cool between applications. This procedure allows the brake shoes to seat into the drum surface.



#### How to Measure Voltage

System voltage is measured at the magnets by connecting the voltmeter to the two magnet lead wires at any brake. This may be accomplished by using a pin probe inserted through the insulation of the wires. The engine of the towing vehicle should be running when checking the voltage so that a low battery will not affect the readings. Voltage in the system should begin at 0 volts and, as the controller bar is slowly actuated, should gradually increase to about 12 volts. If the controller does not produce this voltage control, consult your controller manual. The threshold voltage of a controller is the voltage applied to the brakes when the controller first turns on. Lower threshold voltage will provide for smoother braking. If the threshold voltage is too high, the brakes may feel grabby and harsh.

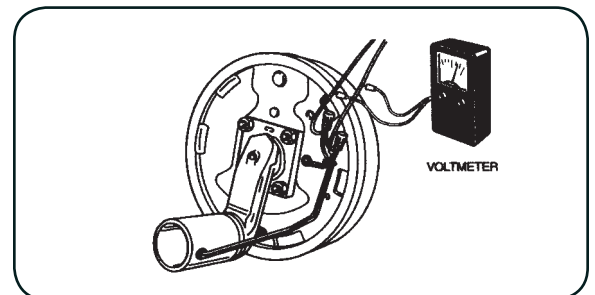

## How to Measure Amperage

System amperage is the current flowing in the system when all the magnets are energized. The amperage will vary in proportion to the voltage. The engine of the tow vehicle should be running with the undercarriage connected when checking the undercarriage braking system. One place to measure system amperage is at the BLUE wire of the controller which is the output to the brakes. The BLUE wire must be disconnected and the ammeter put in series into the line. System amperage draw should be as noted in the table to the right.

Make sure your ammeter has sufficient capacity and note polarity to prevent damaging your ammeter. If a resistor is used in the brake system, it must be set at zero or bypassed completely to obtain the maximum amperage reading. Individual amperage draw can be measured by inserting the ammeter in the line at the magnet you want to check. Disconnect one of the magnet lead wire connectors and attach the ammeter between the two wires. Make sure that the wires are properly reconnected and sealed after testing is completed. The most common electrical problem is low or no voltage and amperage at the brakes. Common causes of this condition are:

1. Poor electrical connections
2. Open circuits
3. Insufficient wire size
4. Broken wires
5. Blown fuses (fusing of brakes is not recommended)
6. Improperly functioning controllers or resistors

Another common electrical problem is shorted or partially shorted circuits (indicated by abnormally high system amperage). Possible causes are:

1. Shorted magnet coils
2. Defective controllers
3. Bare wires contacting a grounded object

Finding the cause of a short circuit in the system is done by isolating one section at a time. If the high amperage reading drops to zero by unplugging the undercarriage, then the short is in the undercarriage. If the amperage reading remains high with all the brake magnets disconnected, the short is in the undercarriage wiring. All electrical troubleshooting procedures should start at the controller. Most complaints regarding brake harshness or malfunction are traceable to improperly adjusted or nonfunctional controllers. See your controller manufacturer's data for proper adjustment and testing procedures. For best results, all the connection points in the brake wiring should be sealed to prevent corrosion. Loose or corroded connectors will cause an increase in resistance which reduces the voltage available for the brake magnets.

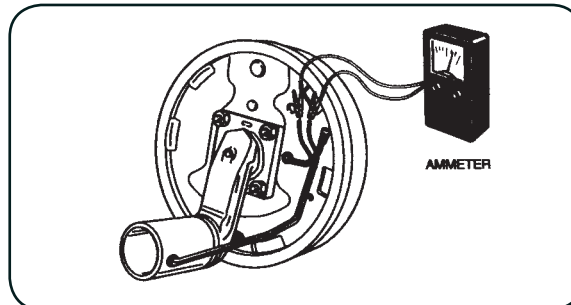

Brake Size	Amps/Magnet	Two Brakes	Four Brakes	Six Brakes	Magnet Ohms
7 x 1¼	2.5	5.0	10.0	15.0	3.9
10 x 1½	3.0	6.0	12.0	18.0	3.2
10 x 2¼	3.0	6.0	12.0	18.0	3.2
12 x 2	3.0	6.0	12.0	18.0	3.2
12¼ x 2½	3.0	6.0	12.0	18.0	3.2



### Brake Drum Inspection

There are two areas of the brake drum that are subject to wear and require periodic inspection. These two areas are the drum surface where the brake shoes make contact during stopping and the armature surface where the magnet contacts (only in electric brakes).

The drum surface should be inspected for excessive wear or heavy scoring. If worn more than .020" oversized, or the drum has worn out of round by more than .015", then the drum surface should be re-machined. If scoring or other wear is greater than .090" on the diameter, the drum must be replaced. When turning the drum surface, the maximum rebore diameter is as follows:

- 7" Brake Drum - 7.090"
- 10" Brake Drum - 10.090"
- 12" Brake Drum - 12.090"

The machined inner surface of the brake drum that contacts the brake magnet is called the armature surface. If the armature surface is scored or worn unevenly, it should be re-faced to a 120 micro inch finish by removing not more than .030" of material. To insure proper contact between the armature face and the magnet face, the magnets should be replaced whenever the armature surface is re-faced and the armature surface should be re-faced whenever the magnets are replaced.

**NOTE:** It is important to protect the wheel bearing bores from metallic chips and contamination which result from drum turning or armature refacing operations. Make certain that the wheel bearing cavities are clean and free of contamination before reinstalling the bearing and seals. The presence of these contaminants will cause premature wheel bearing failure.

### Bearing Inspection

Wash all grease and oil from the bearing cone using a suitable solvent. Dry the bearing with a clean, lint-free cloth and inspect each roller completely.

### Bearing Lubrication

Along with bearing adjustment, proper lubrication is essential to the proper function and reliability of your undercarriage axle. Bearings should be lubricated every 12 months or 12,000 miles. The method to repack the bearing cones is as follows:

1. Place a quantity of grease into the palm of your hand.
2. Press a section of the widest end of the bearing into the outer edge of the grease pile closest to the thumb forcing grease into the interior of the bearing.
3. Repeat this while rotating the bearing from roller to roller.
4. Continue this process until you have the entire bearing completely filled with grease.
5. Before reinstalling, apply a light coat of grease on the bearing cup.

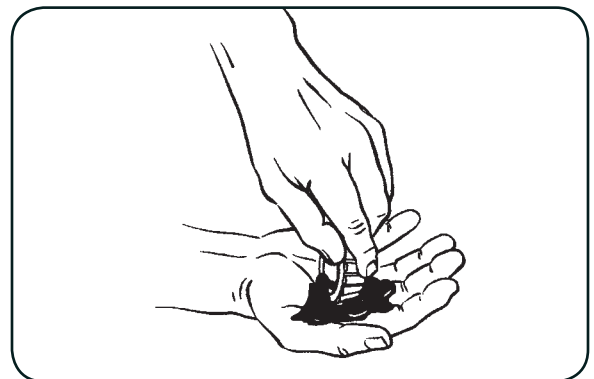

### Troubleshooting Brakes

Most electric brake malfunctions, that cannot be corrected by either brake adjustments or synchronization adjustments, can generally be traced to electrical system failure. Voltmeters and ammeters are essential tools for proper troubleshooting of electric brakes. Mechanical causes are ordinarily obvious, i.e. bent or broken parts, worn out linings or magnets, seized lever arms or shoes, scored drums, loose parts, etc. Please consult the following troubleshooting charts in this section of the manual to determine the causes and solutions for common problems found in undercarriage braking systems.

#### **CAUTION**

- **BEST BRAKING PERFORMANCE IS ACHIEVED WITH A CONTROLLER SETTING THAT IS JUST SHORT OF WHEEL LOCK UP OR SLIDE. OVERLY AGGRESSIVE BRAKING WHICH RESULTS IN WHEEL LOCK UP AND SLIDING, CAN CAUSE A DANGEROUS LOSS OF CONTROL AND RESULT IN PERSONAL INJURY OR DEATH.**

### Battery Warranty

Interstate Battery:  
[www.interstatebatteries.com](http://www.interstatebatteries.com)  
800-CRANKIT



**Belt Stretcher (Optional)**

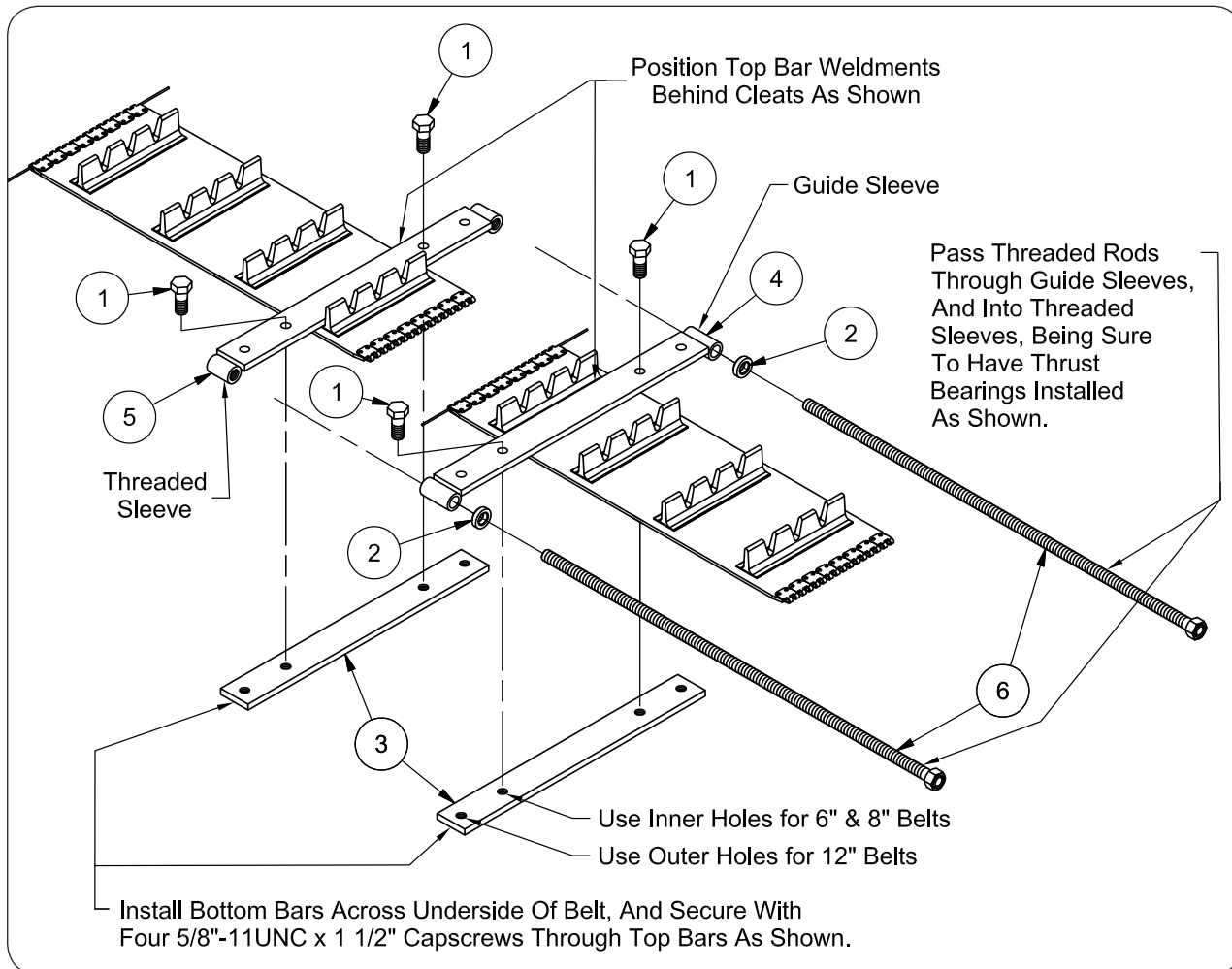

ITEM	PART NO.	QTY	DESCRIPTION
	TA4-114400-0	1	BELT INSTALLATION TOOL
1	9390-122	4	CAPSCREW, 5/8-11UNC x 1 1/2 LG. GRADE 5
2	TA0-903118-0	2	BEARING, BALL THRUST, 5/8" I.D.
3	TA1-114401-0	2	BOTTOM BAR
4	TA2-114404-0	1	PLAIN TOP BAR WELDMENT
5	TA2-114406-0	1	THREADED TOP BAR WELDMENT
6	TA2-114408-0	2	THREAD ROD WELDMENT

**Belt Stretcher (Optional) (Continued)**

**Stretcher Assembled to Belt**

FOR ILLUSTRATION ONLY

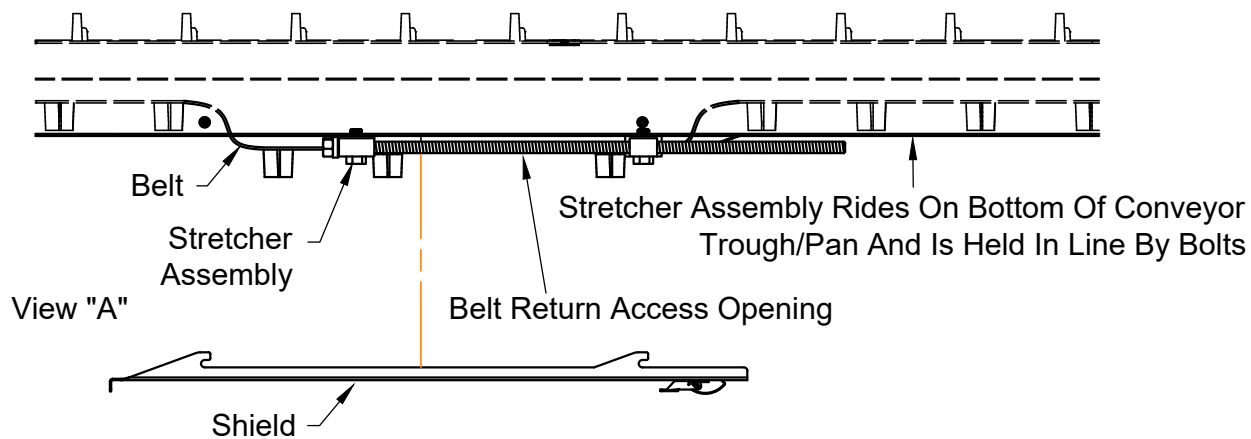
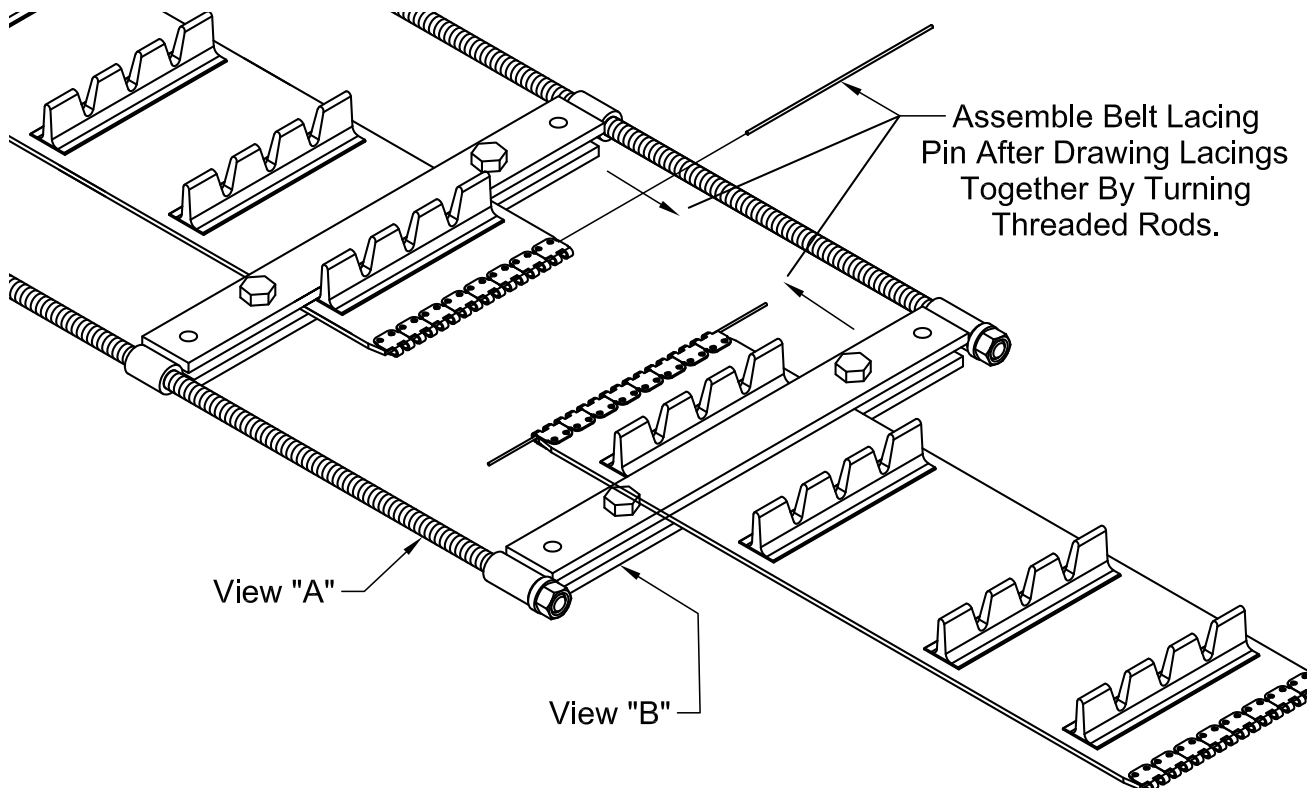

View "B"

Stretcher Assembly Rides On Bottom Of Conveyor Trough/Pan And Is Held In Line By Bolts

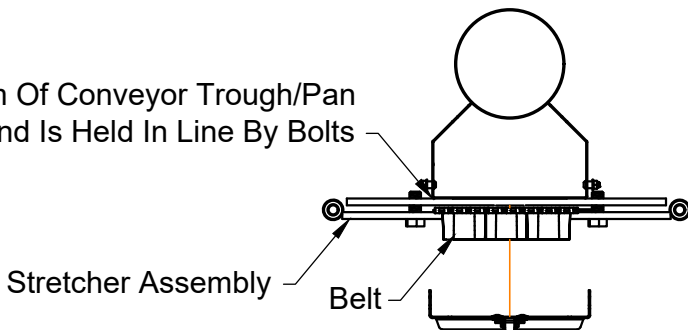

## Wheels & Tires

### Wheel Torque Requirements

#### CAUTION

- IMPROPERLY TORQUED WHEEL NUTS/BOLTS CAN CAUSE A LOSS OF IMPLEMENT CONTROL AND MACHINE DAMAGE. TORQUE WHEEL NUTS/BOLTS TO VALUES IN THE TABLE. CHECK THE TORQUE BEFORE THE INITIAL USE, AFTER ONE HOUR OF UNLOADED USE OR AFTER THE FIRST LOAD, AND EACH LOAD UNTIL THE WHEEL NUTS/BOLTS MAINTAIN THE TORQUE VALUE. CHECK THE TORQUE EVERY 10 HOURS OF USE THEREAFTER. AFTER EACH WHEEL REMOVAL START THE TORQUE PROCESS FROM THE BEGINNING. WARRANTY DOES NOT COVER FAILURES CAUSED BY IMPROPERLY TORQUED WHEEL NUTS/BOLTS.

Failure to check the torque before the first load may damage the wheel nut/bolt seats. Once the seats are damaged, it will become impossible to keep nuts/bolts tight. Tighten the nuts/bolts to the applicable torque value shown to the right. Start all nuts/bolts by hand to prevent cross threading. Torque nuts/bolts in the recommended sequence as shown in Diagram 1.

WHEEL HARDWARE	
SIZE	FOOT-POUNDS
1/2-20 (UNF)	75 FT.-LBS.

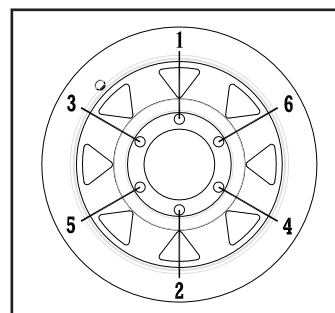

Nut/Bolt Location:	
1/2-20 (UNF)	Single Wheels

### Tire Pressure

The following is to be used as a general guide for tire inflation and figures can vary depending on specific brand of tire used. It is important that the tires are inspected after the unit is loaded. The tire should stand up with no side-wall buckling or distress as the tire rolls. Do not exceed the maximum recommended tire pressure.

235/80R16 LRE....100 PSI maximum  
 235/85R16 LRE....80 PSI maximum  
 (All tire pressures in PSI)

**Wheels & Tires** (continued)

**Tire Warranty**

For questions regarding new tire warranty, please contact your local equipment tire dealer. Used tires carry no warranty. The following are phone numbers and websites for your convenience:

**Greenball**

[www.greenball.com](http://www.greenball.com)  
Phone nearest location:  
California 800-937-5204  
Georgia 800-283-4569  
Florida 800-935-0200  
Indiana 800-426-4068  
Pennsylvania 800-869-6787  
Tennessee 800-946-9412  
Ohio 800-840-7295

**Carlisle**

[www.carlisletire.com](http://www.carlisletire.com)  
Phone 800-260-7959  
Fax 800-352-0075

**Torque Chart**

**Capscrews - Grade 5**

NOTE: Grade 5 capscrews can be identified by three radial dashes on the head.



NOTE: Tighten the U-bolts to have the same number of threads exposed on each end.

SIZE	FOOT POUNDS	NEWTON METERS
1/4-20	8-10	11-13
1/4-28	9-11	12-15
5/16-18	15-17	20-23
5/16-24	17-19	23-26
3/8-16	25-28	34-38
3/8-24	28-31	38-42
7/16-14	40-45	54-61
7/16-20	45-50	61-68
1/2-13	62-68	84-92
1/2-20	68-75	92-102
9/16-12	90-98	122-133
9/16-18	100-110	134-148
5/8-11	120-135	162-183
5/8-18	124-137	168-186
3/4-10	200-220	270-300
3/4-16	210-230	285-310
7/8-9	330-350	425-475
7/8-14	360-380	460-515
1-8	500-525	675-710
1-14	540-560	730-760
1 1/8-7	600-635	815-860
1 1/8-12	665-700	920-950
1 1/4-7	850-895	1150-1215
1 1/4-12	940-990	1275-1340
1 1/2-6	1500-1560	2035-2115
1 1/2-12	1685-1755	2285-2380

### Storage

Your Seed Chariot tender is an important investment. Spend a little time to protect it from destructive rust and corrosion. You will be repaid in longer service life and better performance.

After use, clean out the box, conveyor/auger and hopper. Remove all seed, and pressure wash to remove road dirt, seed treatment, etc.

Prepare the engine for storage. Refer to the engine operator's manual for details.

Check the bolts for tightness. Inspect for damaged or worn parts. Replace or repair items as needed.

Repaint any chipped or scraped areas and store inside away from livestock.

Charge the battery before storage, if applicable. Lack of charge may result in the battery freezing over the winter.

**Troubleshooting**

PROBABLE CAUSE	CORRECTION
<b>UNDERCARRIAGE SWAYING, TIRE WEAR, LIGHTS</b>	
Unit sways during travel	Check tire pressure Check tongue and steering hardware, tighten appropriately
Tires show excessive wear	Check tire pressure
Wheel makes grinding or squeaking noise	Service wheel bearings
Tail lights are not functioning	Check wires and connections Replace lamps
<b>CONVEYOR WILL NOT TURN OVER OR DEVELOP PROPER SPEED OR TORQUE</b>	
Conveyor jammed	Shut-off and lock-out power, open clean-out door and remove excess material (make sure swivel spout is clear)
Engine running too slow	Increase the throttle speed
Conveyor belt slipping	Increase the belt tension - See Adjusting Belt Tension in the Maintenance section
Drive belt slipping	Increase the tension on the drive belt - See Adjusting Drive Belt Tension
<b>AUGER WILL NOT TURN OVER OR DEVELOP PROPER SPEED OR TORQUE</b>	
Auger jammed	Shut off and lock out the power, open the cleanout door and remove excess material. Make sure discharge spout is clear.
Engine running too slow	Increase the throttle speed.
Drive belt slipping	Increase the tension on the drive belt - See Adjusting Drive Belt Tension
<b>BELT EDGES SHOWING EXCESSIVE WEAR</b>	
Belt tracking incorrect	Adjust tracking as detailed in Maintenance section
Poly seals on intake and/or discharge end worn.	Replace poly seals

Front Undercarriage Electrical Schematic — #25045

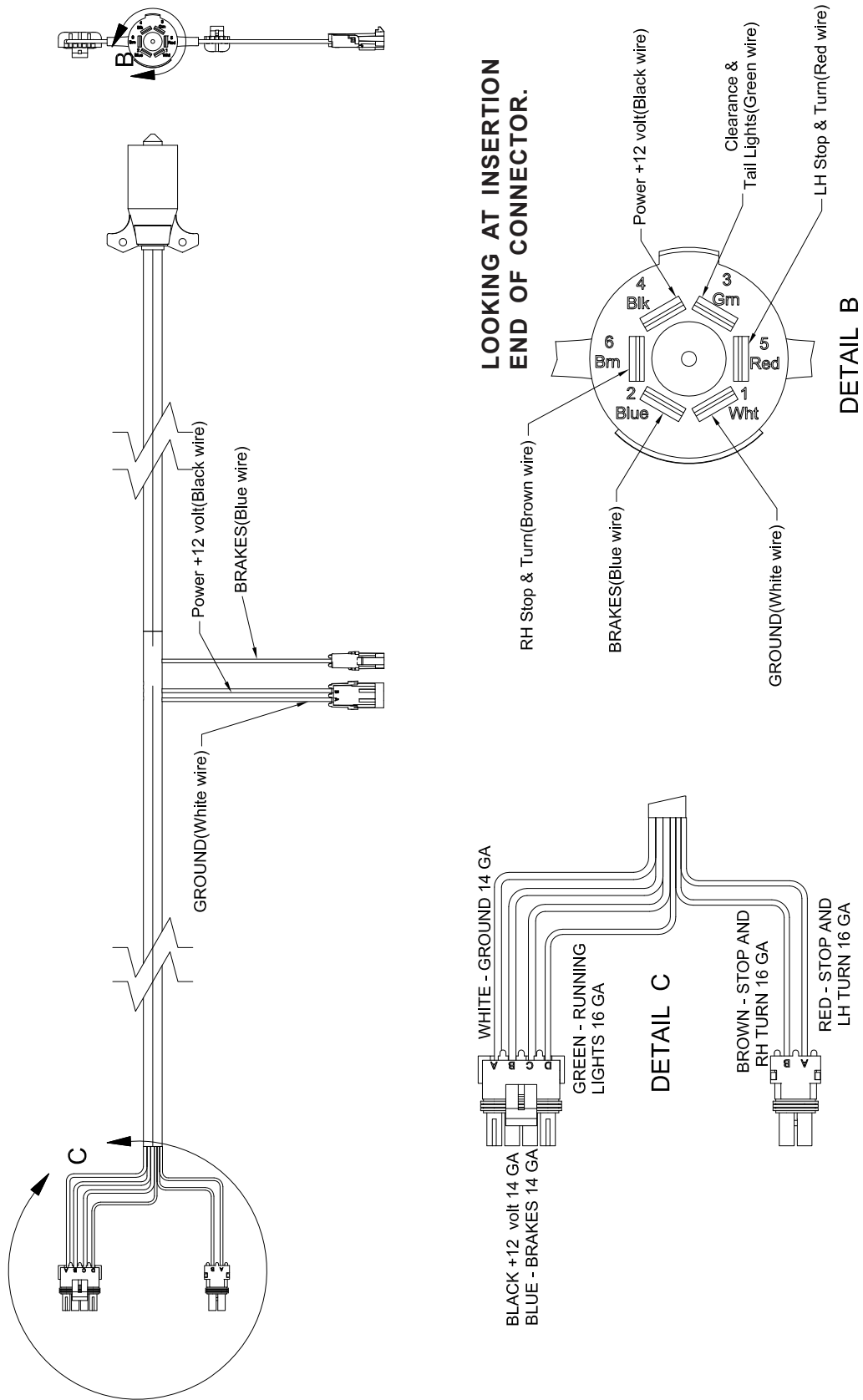



Undercarriage Lighting & Brake Electrical Schematic — #25046

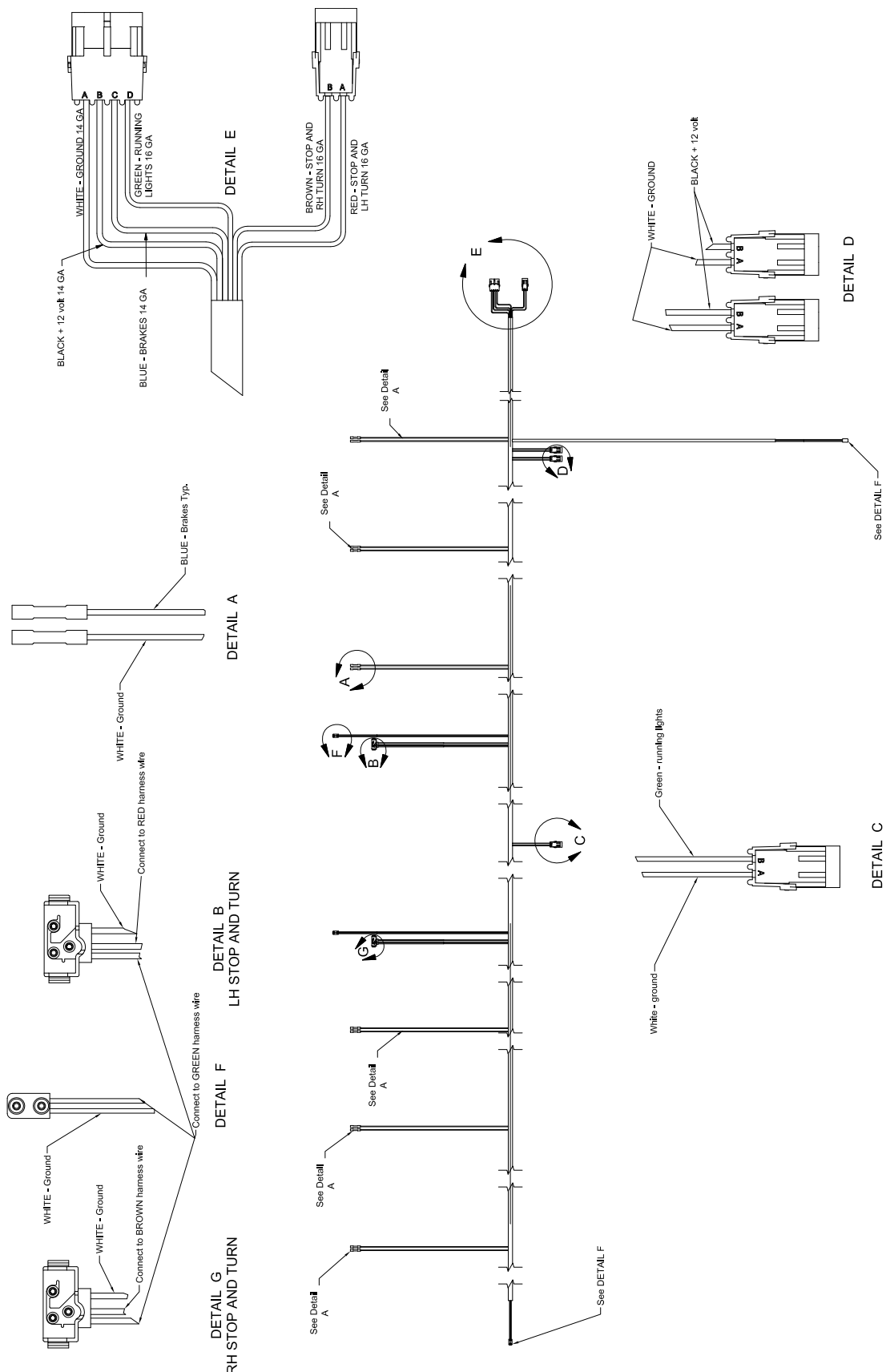

Charge From Truck Electrical Schematic — #29410

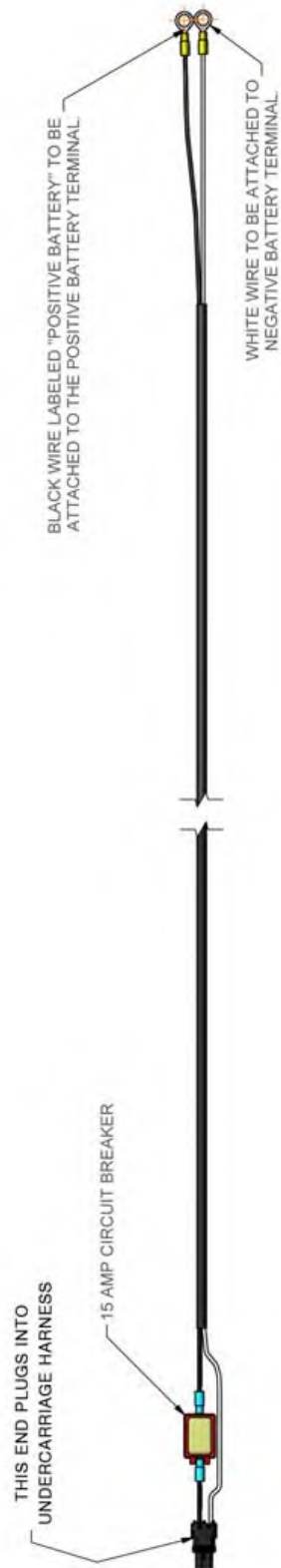

Conveyor or Auger Control Electrical Schematic - #28920

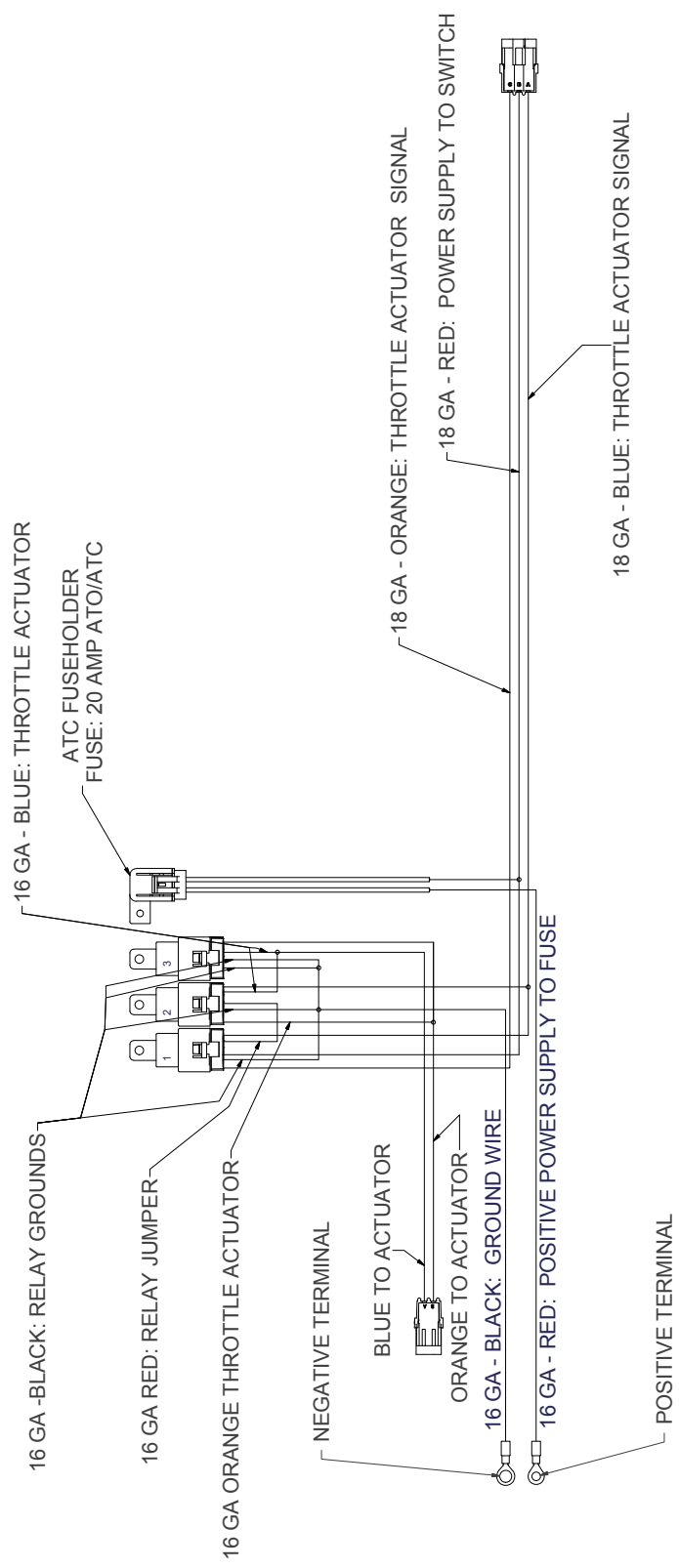

**Conveyor/Auger Control Electrical Schematic #2000588  
For Electric Conveyor/Auger Lift Package**

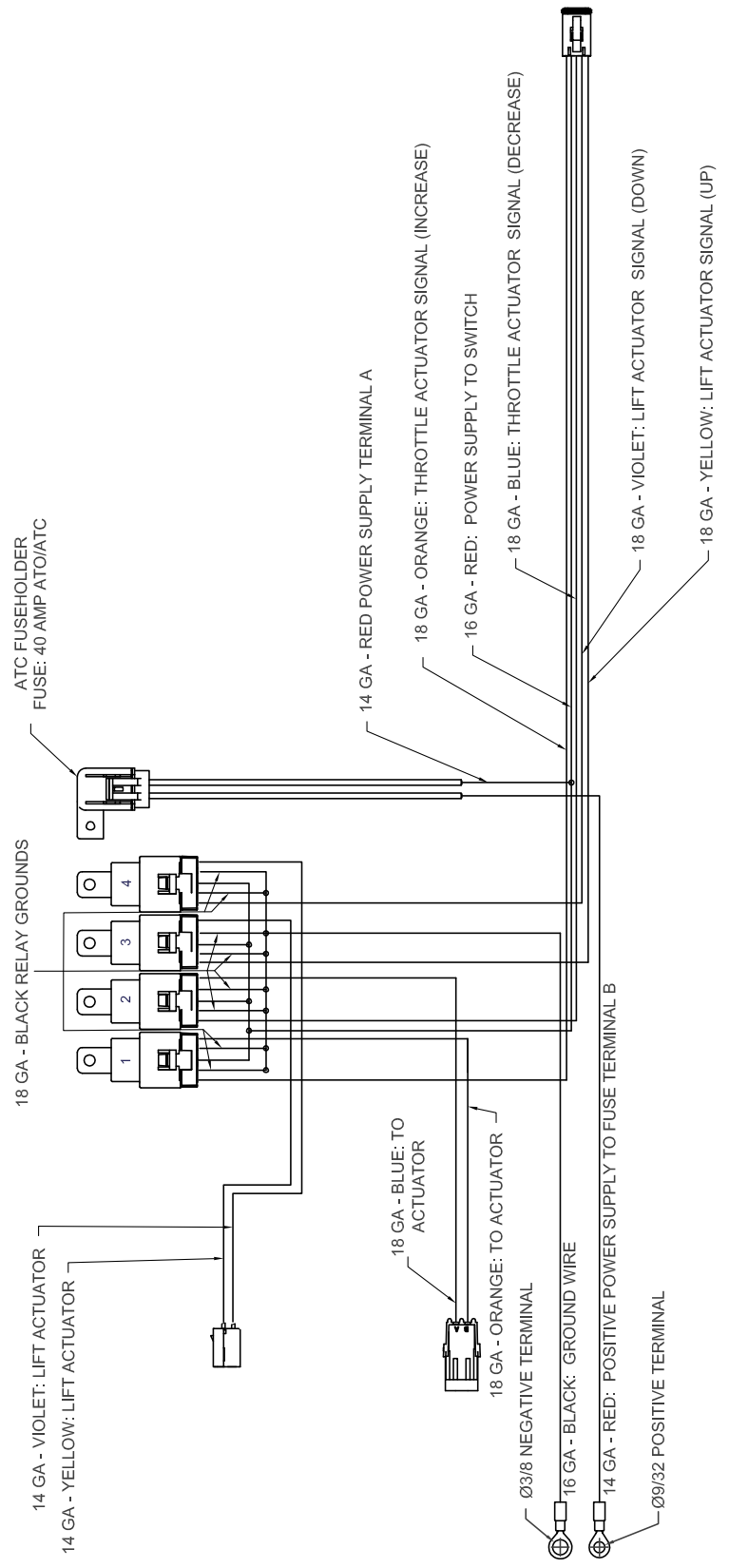

Switch Electrical Schematic — #26734

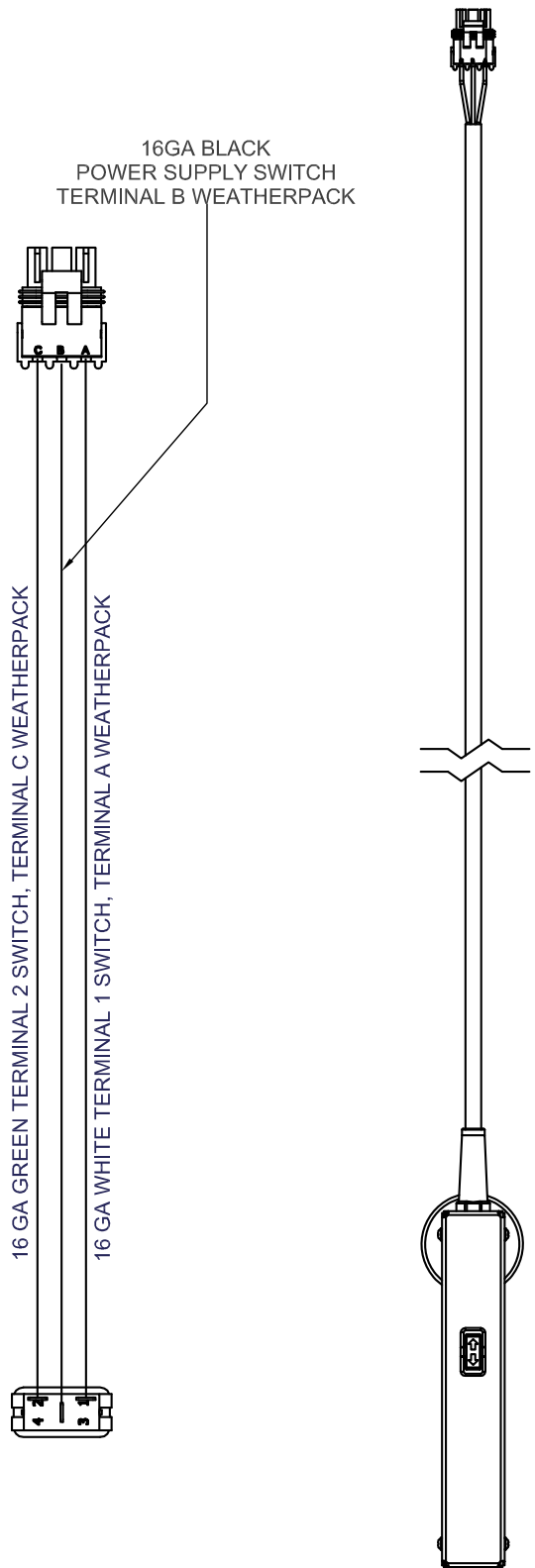

**Switch Electrical Schematic — #2000617  
For Electric Conveyor/Auger Lift Package**

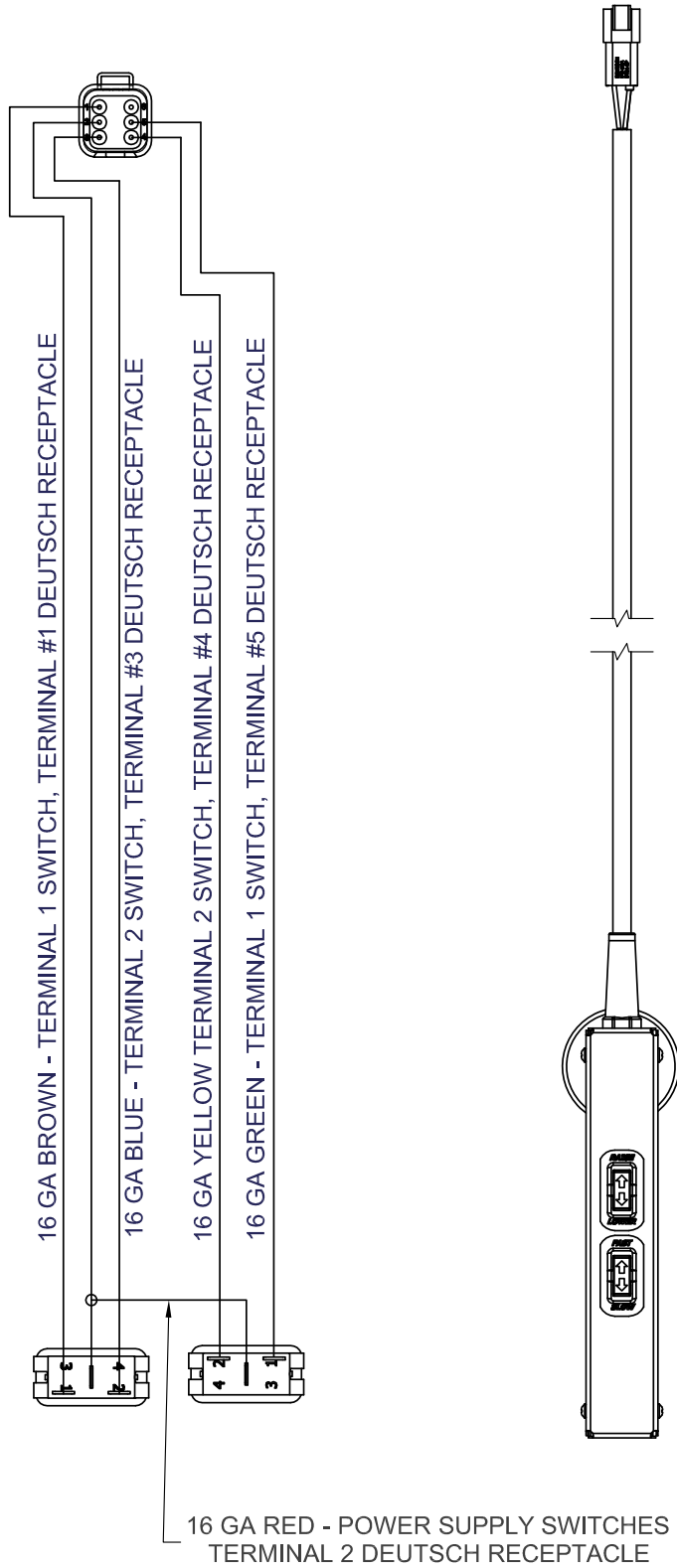

## **Section V Parts**

Decals & Touch-Up Paint.....	5-2
Stationary Bracket Components.....	5-4
Scale Components.....	5-6
Conveyor Drive Assembly & Hopper Components.....	5-8
Conveyor Idler End Components.....	5-12
Conveyor Discharge End Components.....	5-14
Auger Drive Assembly & Hopper Components.....	5-16
U-Joint, Pulley, Engine, & Battery Components .....	5-18
Auger Discharge End Components .....	5-20
Pivot Arm Components .....	5-22
Electric Conveyor Lift Package.....	5-26
Platform Components.....	5-28
Undercarriage, Hitch & Fender Components .....	5-30
Axle & Wheel Components .....	5-34
Spare Tire Kit Components.....	5-35
Telescopic Spout.....	5-36
Platform for Units Less Undercarriage Kit #2003134CG .....	5-38
AG Decal Package (Optional) - SMV, SIS Decals, & Reflectors.....	5-39

Decals & Touch-Up Paint

Please visit [www.unverferth.com/parts/](http://www.unverferth.com/parts/) for the most current parts listing.

Front, Left-Hand View

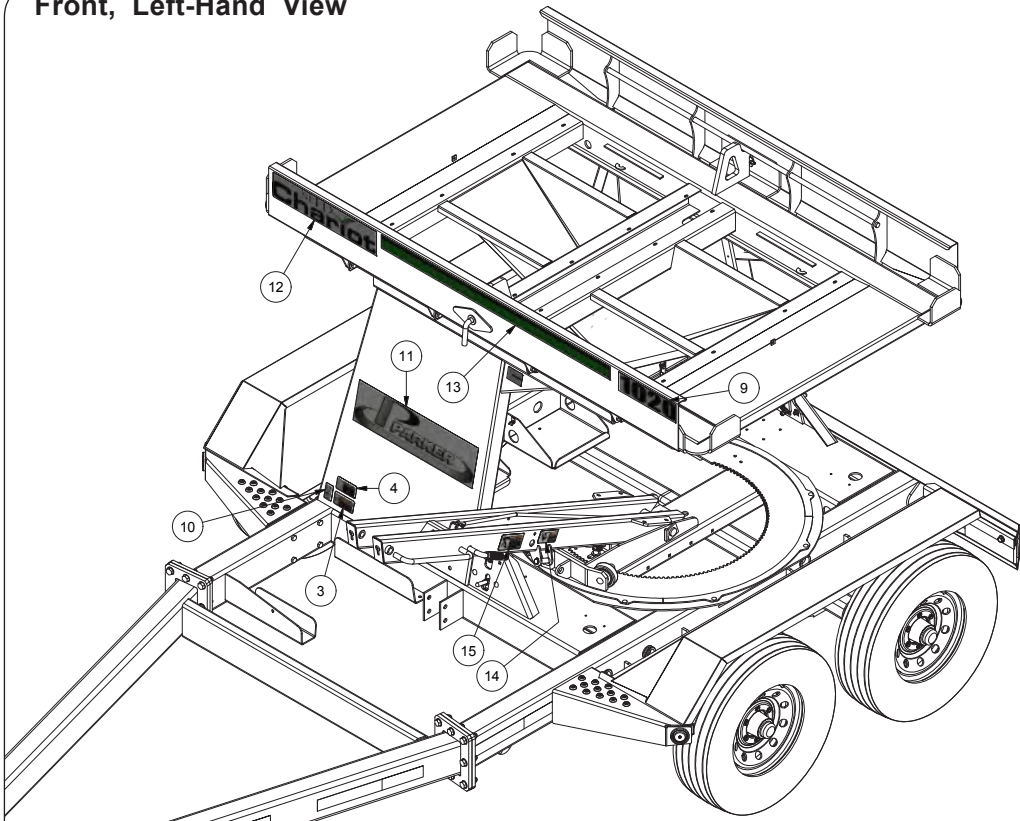

Rear, Right-Hand View

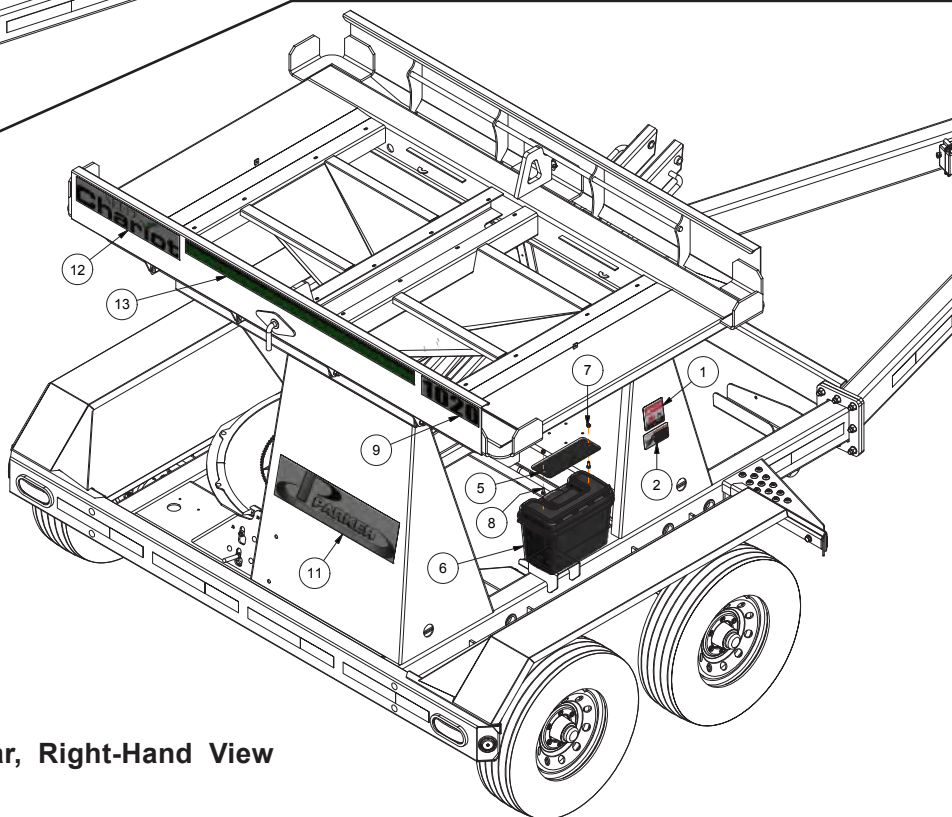



## Seed Chariot 1020 — Parts

### Decals & Touch-Up Paint

Please visit [www.unverferth.com/parts/](http://www.unverferth.com/parts/) for the most current parts listing.

ITEM	PART NO.	DESCRIPTION	QTY	NOTES
1	235161	Decal, DANGER "Flammable"	1	
2	95445	Decal, WARNING "High-Pressure Fluid"	1	
3	97961	Decal, WARNING "Read and Understand"	1	
4	98350	Decal, WARNING "No Riders"	1	
5	27741B	Tool Box Strap	1	
6	902456	Tool Box	1	
7	9807	Locknut 5/16-18UNC	2	
8	9390-028	Capscrew 5/16-18UNC x 3/4	2	Grade 5
9	9500463	Decal, Model 1020	2	
10	91605	Decal, FEMA	1	
11	902934	Decal, PARKER	2	
12	902933	Decal, Seed Chariot	2	
13	902936	Decal, Stripe	2	
14	95839	Decal, WARNING "Pinch Point"	1	
15	98229	Decal, WARNING "Lower Equipment"	1	
16	93705	Clear Silicone Caulk	-	NOT SHOWN
17	9500271	Spray Can - Charcoal Grey	-	NOT SHOWN
18	902996	Spray Can - Dove Grey	-	NOT SHOWN

**Stationary Bracket Components**

Please visit [www.unverferth.com/parts/](http://www.unverferth.com/parts/) for the most current parts listing.

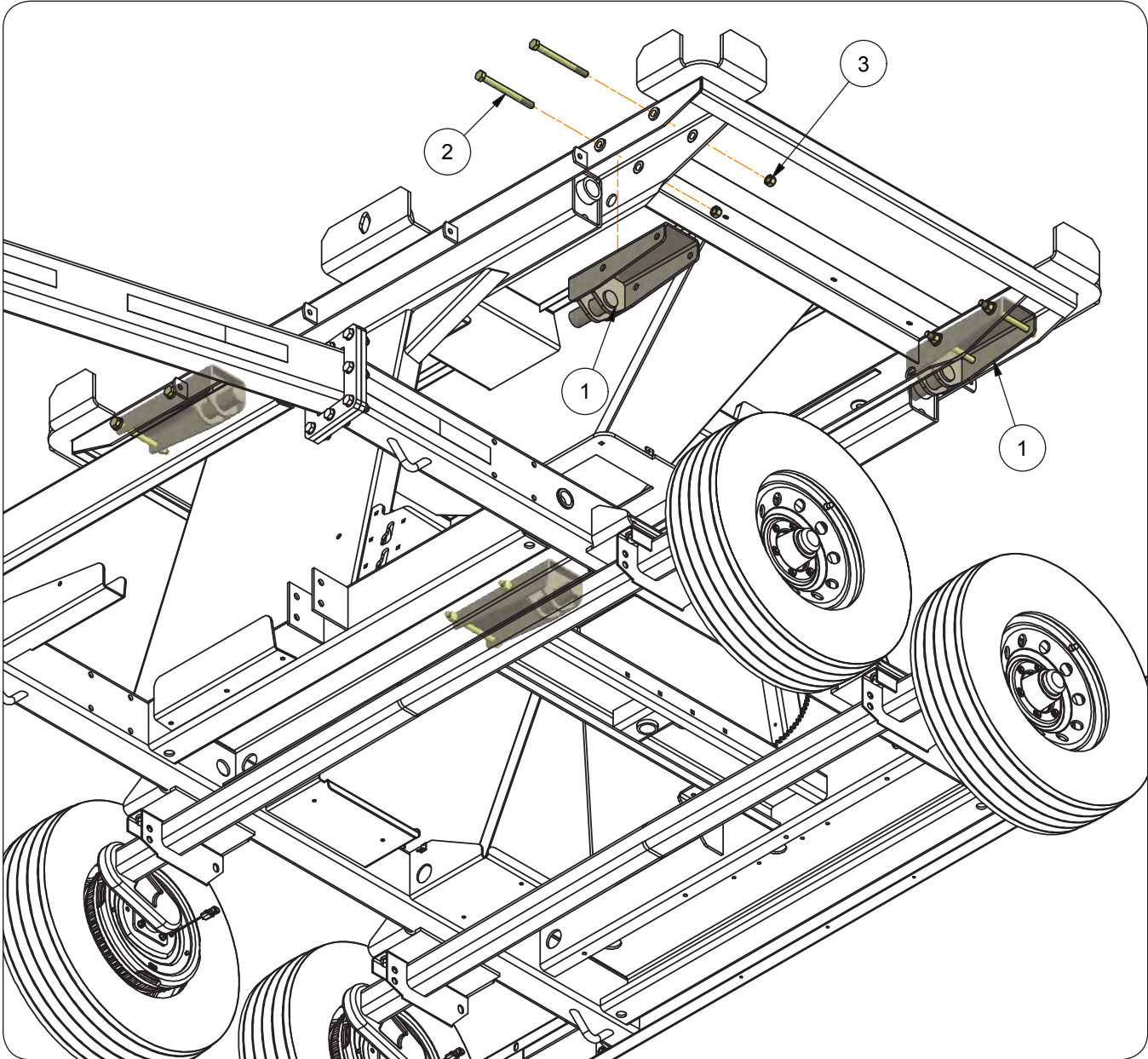

## Stationary Bracket Components

Please visit [www.unverferth.com/parts/](http://www.unverferth.com/parts/) for the most current parts listing.

ITEM	PART NO.	DESCRIPTION	QTY	NOTES
1	29070CG	Stationary Bracket	4	
2	9390-138	Capscrew 5/8-11UNC x 7	8	Grade 5
3	9801	Locknut 5/8-11UNC	8	

Scale Components

Please visit [www.unverferth.com/parts/](http://www.unverferth.com/parts/) for the most current parts listing.

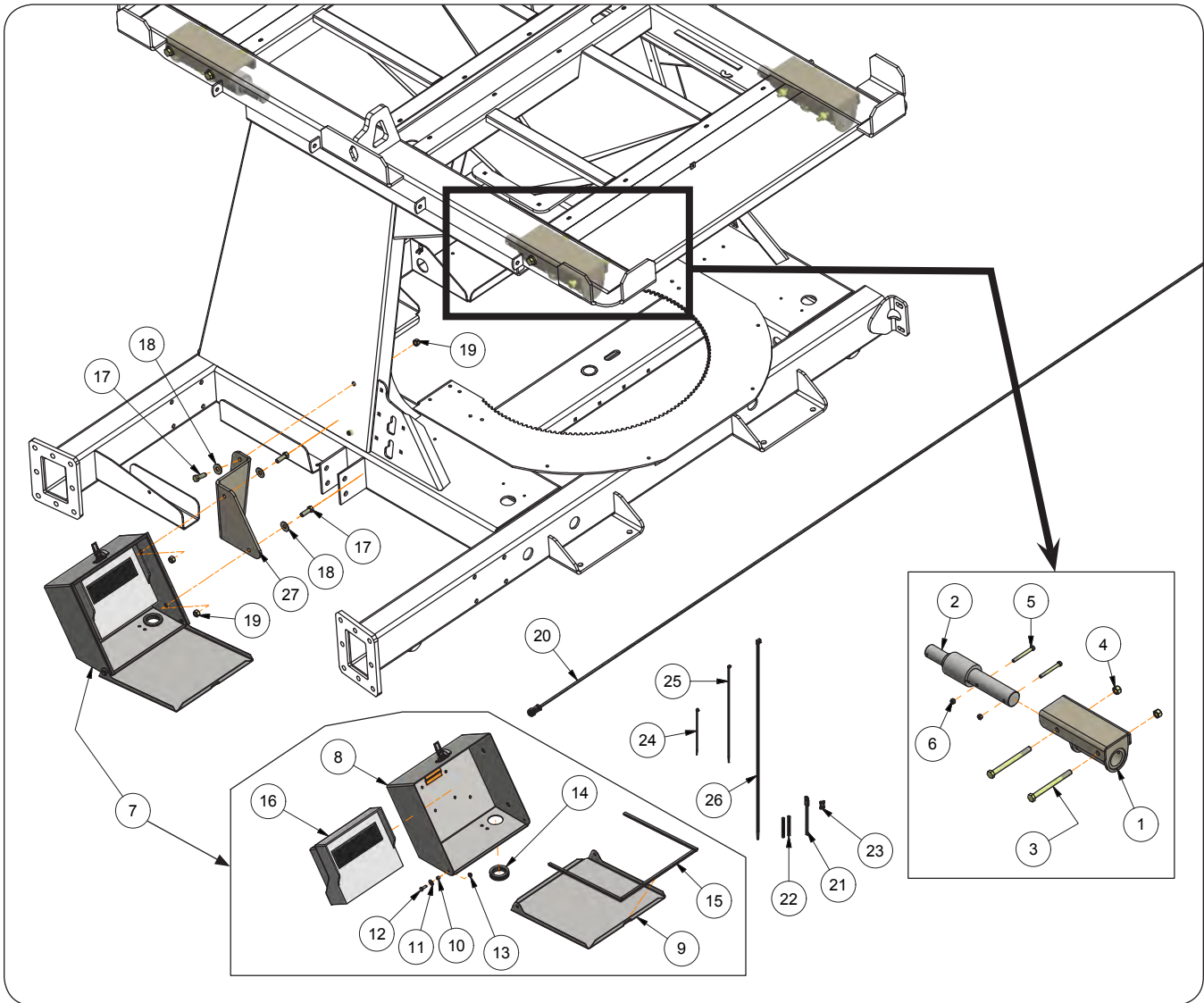

## Seed Chariot 1020 — Parts

### Scale Components

Please visit [www.unverferth.com/parts/](http://www.unverferth.com/parts/) for the most current parts listing.

ITEM	PART NO.	DESCRIPTION	QTY	NOTES
1	29065CG	Scale Bracket Weldment	4	
2	902063	Weigh Bar - 2 1/8" Dia. w/ 21' Cable	4	
3	9390-138	Capscrew 5/8-11UNC x 7	16	Grade 5
4	9801	Locknut 5/8-11UNC	16	
5	9390-065	Capscrew 3/8-16UNC x 3 1/2	16	Grade 5
6	9928	Locknut 3/8-16UNC	16	
7	28945CG	Scale Enclosure Assembly	1	Includes items 8-16
8	28944CG	Scale Enclosure Weldment	1	
9	28943CG	Scale Enclosure Cover	1	
10	22018	Bushing	2	
11	9405-064	Flat Washer 1/4" USS	2	
12	9390-003	Capscrew 1/4-20UNC x 3/4	4	Grade 5
13	9936	Locknut 1/4-20UNC	4	
14	900513	Grommet/Rubber 2" Dia.	1	
15	25062	Foam Strip	3	
16	902062	Scale Indicator - Model 640XL	1	
17	9390-101	Capscrew 1/2-13UNC x 1 1/2	2	Grade 5
18	9405-088	Flat Washer 1/2" USS	2	
19	9800	Locknut 1/2-13UNC	2	
20	902087	Scale Power Cord	1	
21	21903	Connector	1	
22	26554	Heat Shrink Tube	2	
23	91023	Butt Connector	2	
24	9000106	Cable Tie 6"	16	
25	9000107	Cable Tie 15 1/2"	6	
26	94038	Cable Tie 32"	2	
27	29267CG	Scale Bracket	1	

Conveyor Drive Assembly & Hopper Components

Please visit [www.unverferth.com/parts/](http://www.unverferth.com/parts/) for the most current parts listing.

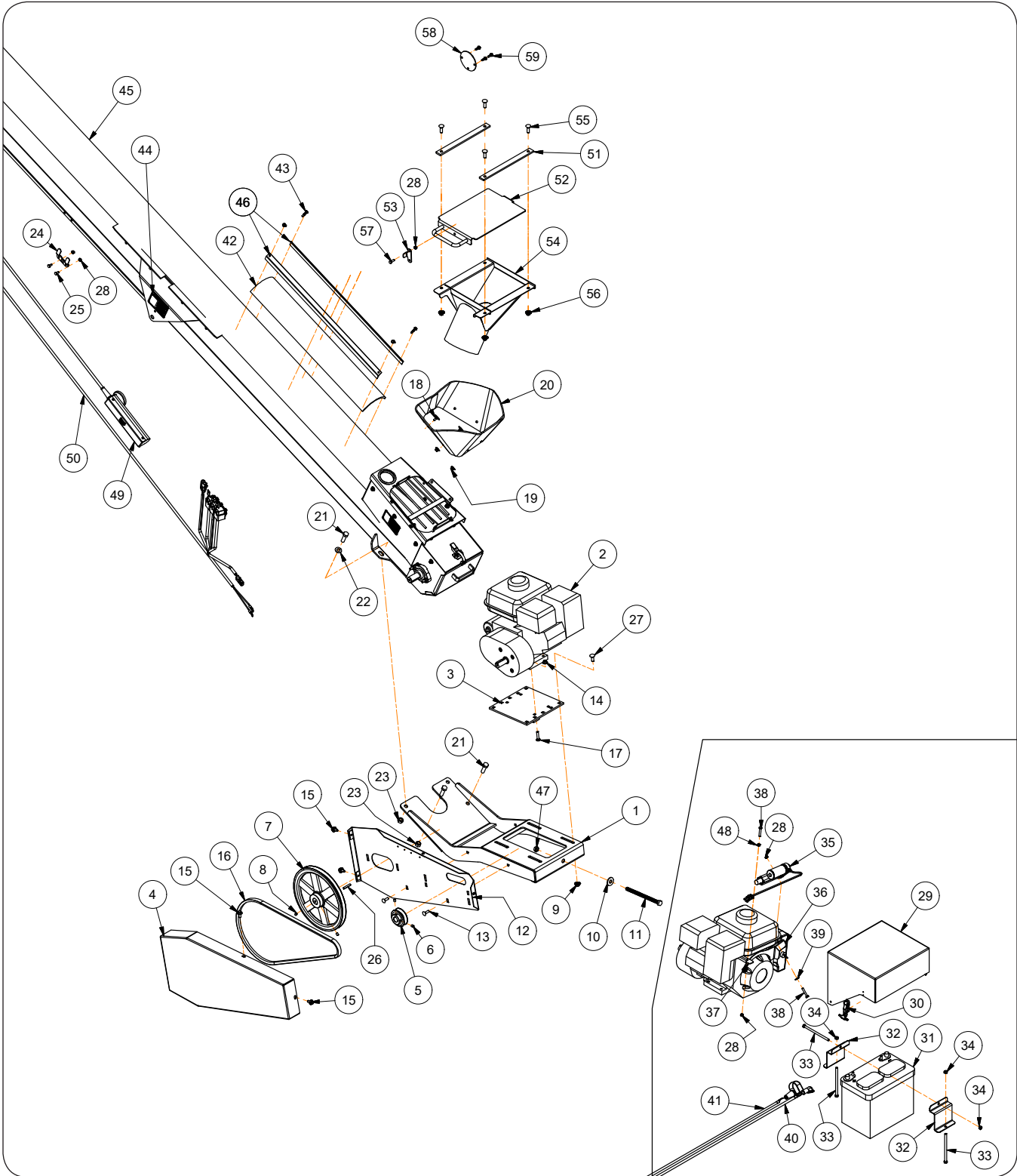

## Seed Chariot 1020 — Parts

### Conveyor Drive Assembly & Hopper Components

Please visit [www.unverferth.com/parts/](http://www.unverferth.com/parts/) for the most current parts listing.

ITEM	PART NO.	DESCRIPTION	QTY	NOTES
1	29150CG	Engine Mount Weldment	1	
2	901673	Honda Engine 4.8 Net HP Gas, 9.9 Cu. In.	1	
	901333	Key/Ignition Replacement	-	
	903057	Key on Output Shaft	-	
3	28377CG	Adjustment Plate	1	
4	29160CG	Shield Weldment	1	
5	902059	Pulley 2.95 Dia. w/ Set Screws	1	
6	9399-071	Set Screws 5/16-18UNC x 3/8	2	
7	901659	Pulley/Sheave w/ Set Screws	1	
8	9399-071	Set Screws 5/16-18UNC x 3/8	2	
9	91263	Large Flange Nut 3/8-16UNC	4	
10	9405-088	Flat Washer 1/2" USS	2	
11	TA0-907228-0	Capscrew 1/2-13UNC x 7 1/2	1	Full Threaded
12	29157CG	Shield Weldment	1	
13	9388-025	Carriage Bolt 5/16-18UNC x 1	4	
14	91257	Flange Nut 5/16-18UNC	4	
15	91256	Large Flange Screw 5/16-18UNC x 3/4	4	
16	903115	V-Belt - 58" Outer Length	1	
17	9500341	Carriage Bolt 5/16"-18UNC x 1 3/4"	4	Full Threaded
18	902006	Elevator Bolt 1/4"-20UNC x 3/4"	8	
19	97189	Large Flange Hex Nut 1/4-20UNC	8	
20	26689	Rubber Hopper	1	
21	9390-102	Capscrew 1/2-13UNC x 1 3/4	4	
22	9405-086	Flat Washer 1/2 SAE	2	
23	9800	Locknut 1/2-13UNC	4	
24	26505	Switch Retainer	1	
25	9390-001	Capscrew 1/4-20UNC x 1/2	2	Grade 5
26	800713	Key 1/4 x 1/4 x 1 1/2	1	
27	9388-053	Carriage Bolt 3/8-16UNC x 1 1/2	4	Grade 5
28	9936	Locknut 1/4-20UNC	5	
29	28419CG	Battery Cover	1	
30	104988	Draw Latch	2	
31	902775	Battery 12V	1	
32	28418B	Battery Bracket	2	
33	9390-045	Capscrew 5/16-18UNC x 5 1/2	3	Grade 5
34	9807	Locknut 5/16-18UNC	3	

(Continued on next page)

## Seed Chariot 1020 — Parts

### Conveyor Drive Assembly & Hopper Components (continued)

Please visit [www.unverferth.com/parts/](http://www.unverferth.com/parts/) for the most current parts listing.

ITEM	PART NO.	DESCRIPTION	QTY	NOTES
35	2008982	Actuator Replacement Kit	1	
36	2008983CG	Throttle Bracket	1	
37	26719CG	Angle for Actuator Assembly For 6" Tube Conveyor	1	
38	9390-007	Capscrew 1/4"-20UNC x 1 1/2" G5	2	
	9390-008	Capscrew 1/4"-20UNC x 1 3/4" G5	1	
39	9405-064	Flat Washer 1/4" USS	1	
40	9500551	Battery Cable (Red)	1	
41	9500552	Battery Cable (Black)	1	
42	27925	Wear Guard	1	
43	9512	Self-Drilling Screw 1/4-14 x 1	4	
44	901478	Decal, DANGER "Electrocution"	2	
45	2005359CG	Conveyor Tube 6" x 18' with Decals		
46	N/A	Plate	2	
47	9395-010	Hex Jam Nut 1/2"-13UNC	1	
48	9394-002	Hex Nut 1/4"-20UNC	1	
49	26734	Switch Assembly 198"	1	
50	28920	Wire Harness	1	
51	29261CG	Bar 11 1/2" Long	2	
52	29078CG	Door Weldment	1	
53	25977B	Latch Plate	1	
54	29255CG	Chute Weldment	1	
55	9388-052	Carriage Bolt 3/8-16UNC x 1 1/4	4	Grade 5
56	91263	Large Flange Nut 3/8-16UNC	4	
57	9390-003	Capscrew 1/4-20UNC x 3/4	1	Grade 5
58	2001622DG	Cover Plate	1	
59	9473	Self-Drilling Screw 1/4-14 x 3/4	3	



**Notes**

Conveyor Idler End Components

Please visit [www.unverferth.com/parts/](http://www.unverferth.com/parts/) for the most current parts listing.

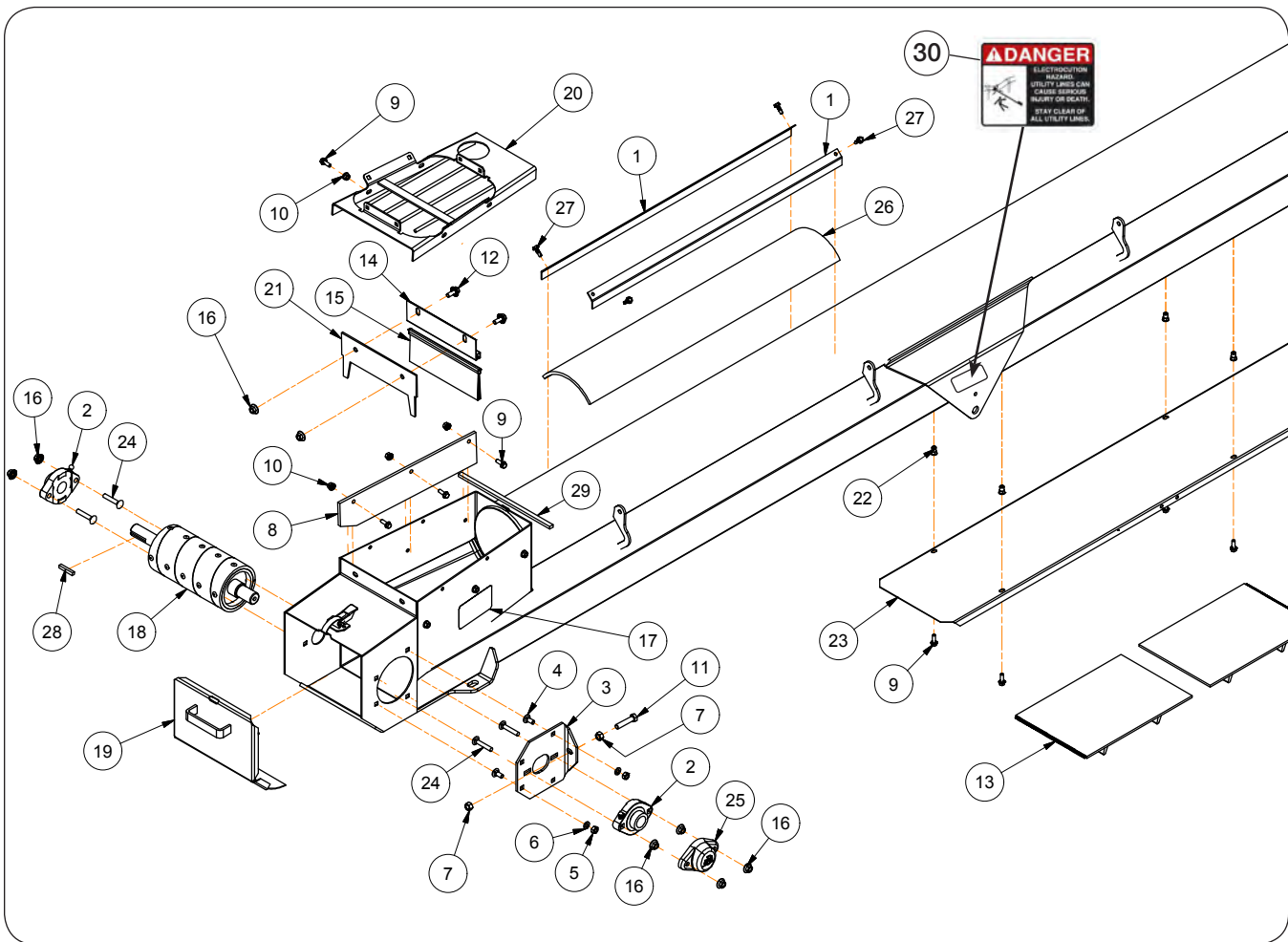

## Seed Chariot 1020 — Parts

### Conveyor Idler End Components

Please visit [www.unverferth.com/parts/](http://www.unverferth.com/parts/) for the most current parts listing.

ITEM	PART NO.	DESCRIPTION	QTY	NOTES
	2005359CG	Conveyor Tube 6" x 18' with Decals	-	
1	N/A	Plate/Strap	2	
2	TA0-903088-0	Bearing w/Flange 1" I.D.	2	
3	23912CG	Adjustment Plate	1	
4	9388-024	Carriage Bolt 5/16-18UNC x 3/4	4	Grade 5
5	9394-004	Hex Nut 5/16-18UNC	4	
6	9404-019	Lock Washer 5/16	4	
7	9394-006	Hex Nut 3/8-16UNC	2	
8	24756	Poly Strip	1	
9	97420	Flange Screw 1/4-20UNC x 3/4	13	
10	97189	Large Flange Hex Nut 1/4-20UNC	3	
11	TA0-907104-0	Capscrew 3/8-16UNC x 1 3/4	1	Grade 5 - Full Threaded
12	91256	Large Flange Screw 5/16-18UNC x 3/4	2	
13	900779	Conveyor Belt	1	
	9500087	Belt Splice Pin For Clipper Style Splice	-	
	28982	In Field Splice Repair For Alligator Splice	-	
14	24964	Brush Holder	1	
15	901111	Nylon Brush	1	
16	91257	Large Flange Hex Nut 5/16-18UNC	2	
17	TA1-906109-0	Decal, WARNING (Moving Parts...)	2	
18	901661	Drive Pulley	1	
	800713	Key 1/4 x 1/4 x 1 1/2	1	
19	26002CG	Cleanout Door Weldment	1	
20	26688CG	Cover Weldment	1	
21	26865	Seal	1	
22	902340	Rivet Nut 1/4-20UNC	10	
23	2010579CG	Bottom Shield	1	
24	9500341	Carriage Bolt 5/16-18UNC x 1 3/4	4	Grade 5
25	9500310	Idler Cover	2	
26	27925	Wear Guard	1	
27	9473	Self-Drilling Screw 1/4-14 x 3/4	4	
28	800713	Key 1/4 x 1/4 x 1 1/2	1	
29	900152	Foam Strip	1	
30	901478	Decal, DANGER "Electrocution"	2	

Conveyor Discharge End Components

Please visit [www.unverferth.com/parts/](http://www.unverferth.com/parts/) for the most current parts listing.

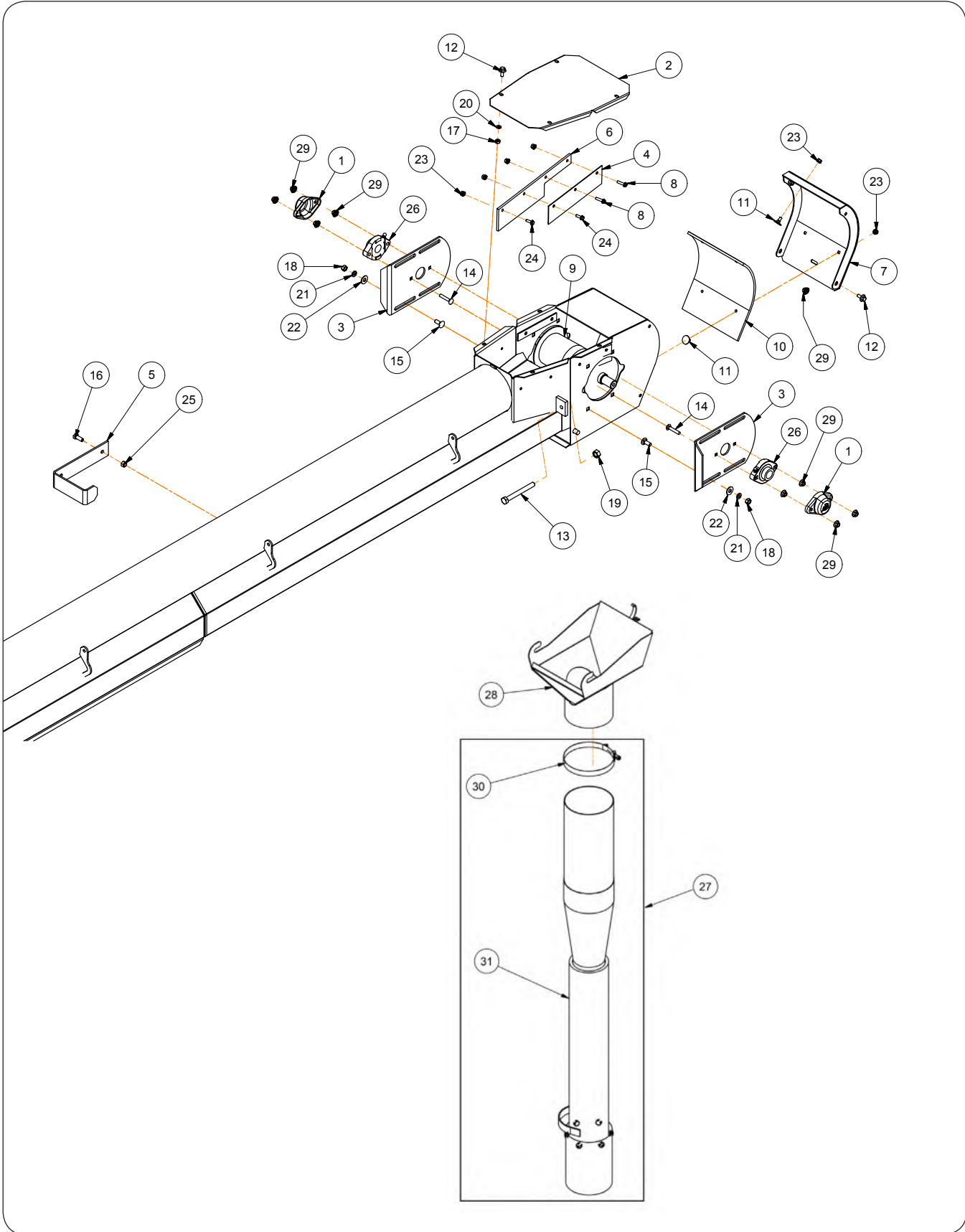

## Conveyor Discharge End Components

Please visit [www.unverferth.com/parts/](http://www.unverferth.com/parts/) for the most current parts listing.

ITEM	PART NO.	DESCRIPTION	QTY	NOTES
1	9500310	Idler Cover	2	
2	23918CG	Top Shield/Cover	1	
3	23994CG	Adjustment Plate	2	
4	24260	Seal	2	
5	24414CG	Spout Bracket	1	
6	24755	Poly Strip	2	
7	26580CG	Deflector Weldment	1	
8	901101	Flange Screw 1/4-20UNC x 1	4	
9	901662	Idler Pulley	1	
10	901723	Neoprene	1	
11	902006	Elevator Bolt 1/4-20UNC x 3/4	4	
12	91256	Large Flange Screw 5/16-18UNC x 3/4	4	
13	93400	Capscrew 1/2-13UNC x 4 1/2	2	Grade 5-Full Threaded
14	9500341	Carriage Bolt 5/16-18UNC x 1 3/4	4	Grade 5-Full Threaded
15	9388-051	Carriage Bolt 3/8-16UNC x 1	8	Grade 5
16	9390-055	Capscrew 3/8-16UNC x 1	1	Grade 5
17	9394-004	Hex Nut 5/16-18UNC	4	
18	9394-006	Hex Nut 3/8-16UNC	8	
19	9394-010	Hex Nut 1/2-13UNC	2	
20	9404-019	Lock Washer 5/16	4	
21	9404-021	Lock Washer 3/8	8	
22	9405-076	Flat Washer 3/8 USS	8	
23	97189	Large Flange Hex Nut 1/4-20UNC	8	
24	97420	Flange Screw 1/4-20UNC x 3/4	4	
25	9928	Locknut 3/8-16UNC	1	
26	TA0-903088-0	Bearing w/Flange 1" I.D.	2	
27	28953CG	Telescopic Spout Assembly	1	Includes Items 30, 31
28	26585CG	Spout Weldment	1	
29	91257	Flange Nut 5/16-18UNC	10	
30	98060	Camp/T-Bolt	1	
31	27629	Telescopic Spout 60" Long	1	

Auger Drive Assembly & Hopper Components

Please visit [www.unverferth.com/parts/](http://www.unverferth.com/parts/) for the most current parts listing.

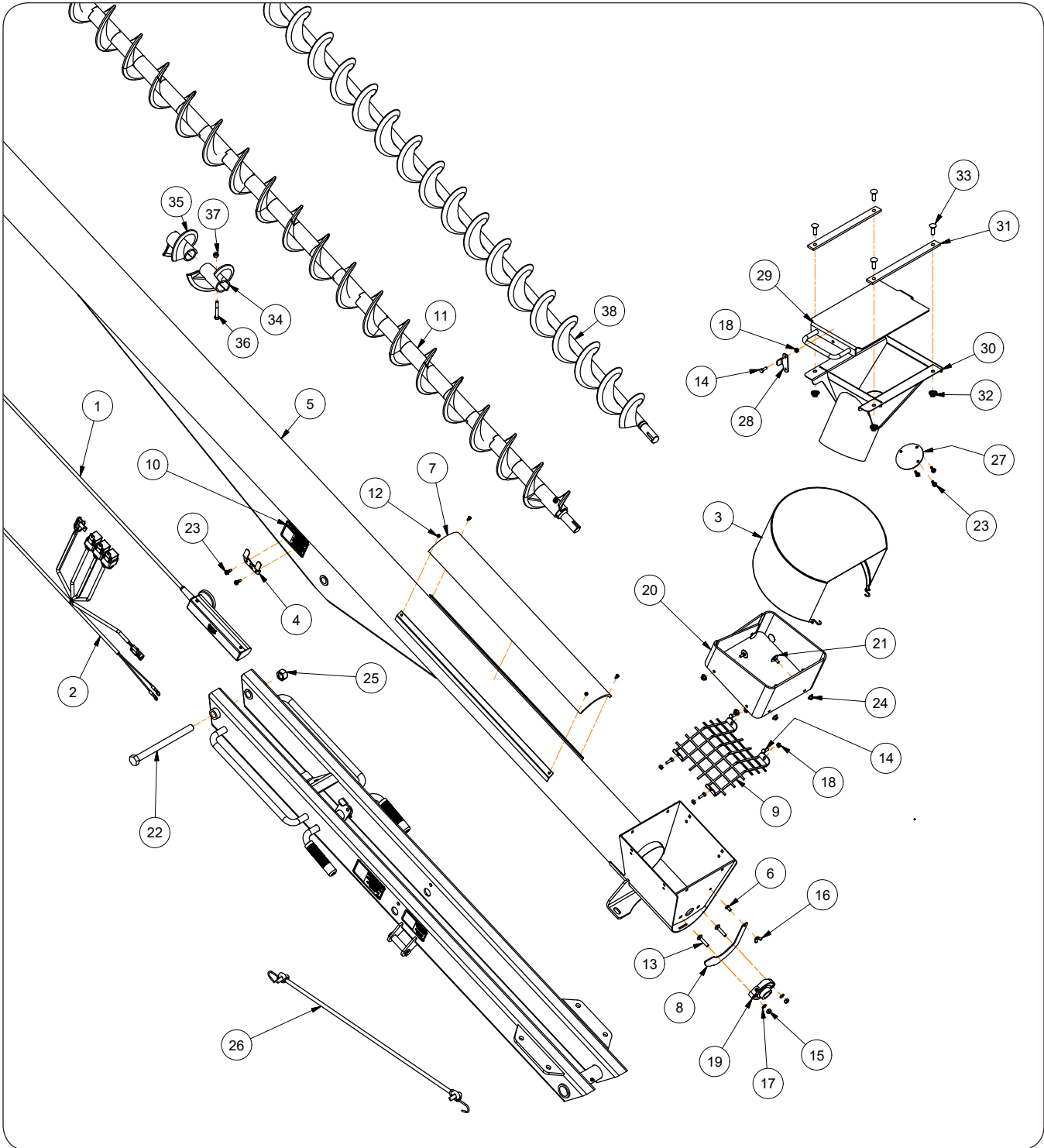

## Seed Chariot 1020 — Parts

### Auger Drive Assembly & Hopper Components

Please visit [www.unverferth.com/parts/](http://www.unverferth.com/parts/) for the most current parts listing.

ITEM	PART NO.	DESCRIPTION	QTY	NOTES
1	26734	Switch Assembly 198"	1	
2	28920	Wire Harness	1	
3	2000399	Vinyl Cover	1	
4	26505	Switch Retainer	1	
5	2005356CG	Auger Tube 6" x 18' with Decals	-	
6	9390-001	Capscrew 1/4-20UNC x 1/2	1	
7	27925	Wear Guard	1	
8	29374CG	Cleanout Door	1	
9	29393CG	Grate Weldment	1	
10	901478	Decal, DANGER "Electrocution"	2	
11	903225	Plastic Flight Assembly	1	
12	91005	Self-Tapping Screw #10-24 x 3/8	4	
13	9388-027	Carriage Bolt 5/16"-18UNC x 1 1/2" G5		
14	9390-003	Capscrew 1/4"-20UNC x 3/4" G5	1	
15	9394-004	Hex Nut 5/16-18UNC	2	
16	9396-015	Wing Nut 1/4-20UNC	1	
17	9404-019	Lock Washer 5/16"	2	
18	9936	Locknut 1/4-20UNC	3	
19	TA0-903088-0	Bearing w/Flange 1" ID	2	
20	29936	Rubber Hopper	1	
21	902006	Elevator Bolt 1/4"-20UNC x 3/4"	8	
22	9390-687	Capscrew 3/4"-10UNC x 9 1/2"	1	
23	9473	Self-Drilling Screw 1/4-14 x 3/4"	2	
24	97189	Large Flange Hex Nut 1/4"-20UNC	8	
25	9802	Locknut 3/4"-10UNC	1	
26	105220	Universal Tarp Strap	1	
27	2001622DG	Plate =Dove Grey=	1	
28	25977B	Latch Plate	1	
29	29078CG	Door Weldment	1	
30	29255CG	Chute Weldment	1	
31	29261CG	Bar 11 1/2" Long	2	
32	91263	Large Flange Nut 3/8-16UNC	4	
33	9388-052	Carriage Bolt 3/8-16UNC x 1 1/4	10	
34	901122	Flight Section w/Gusset	2	
35	900199	Flight Section	49	
36	91484	Capscrew 5/16-18UNC x 2 1/4 (Stainless Steel)	2	
37	92929-007	Elastic Stop Nut 5/16-18UNC (Stainless Steel)	2	
38	2002755B	Steel Flighting Weldment	1	

**U-Joint, Pulley, Engine, & Battery Components**

Please visit [www.unverferth.com/parts/](http://www.unverferth.com/parts/) for the most current parts listing.

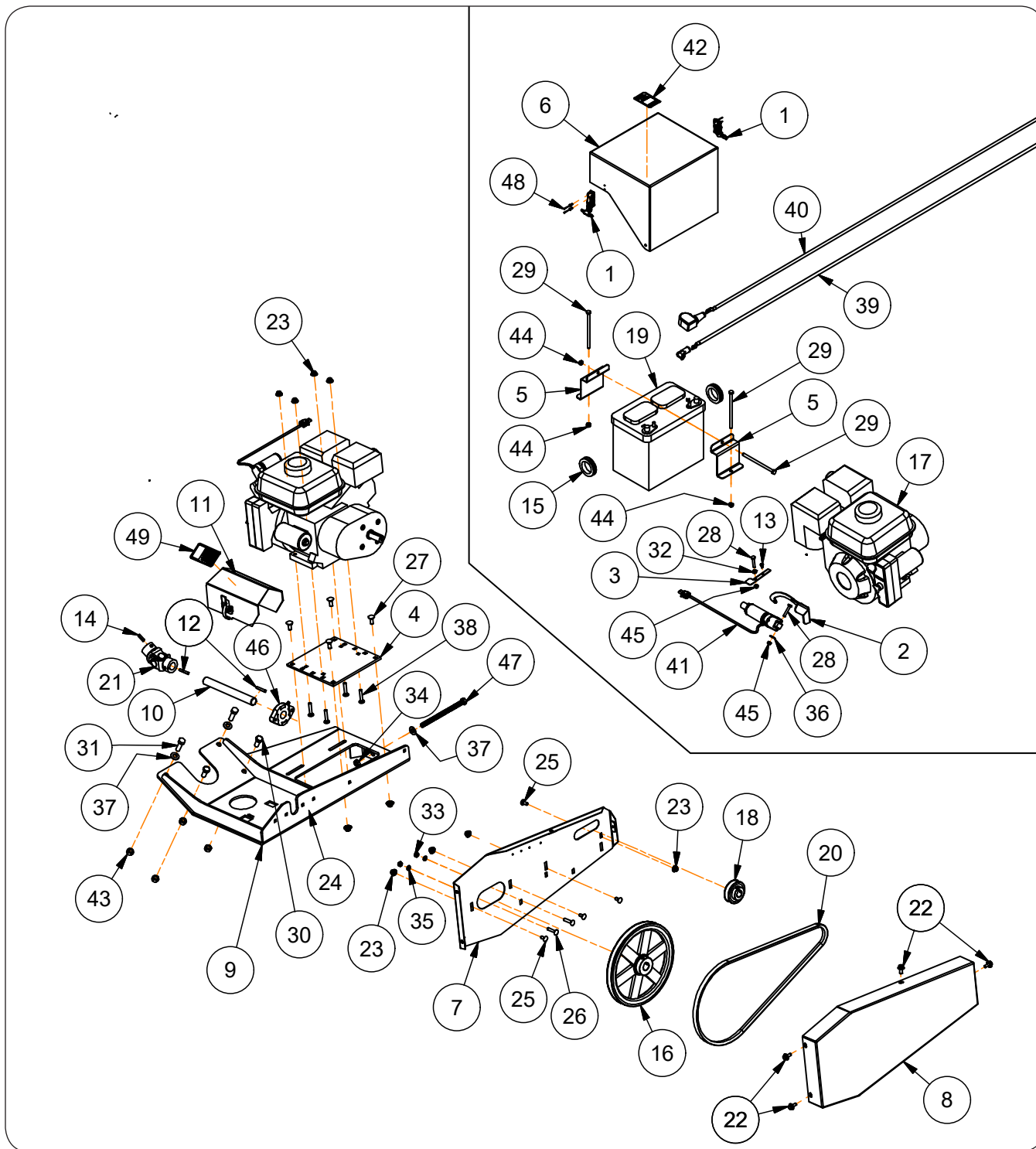

ITEM	PART NO.	DESCRIPTION	QTY	NOTES
1	104988	Draw Latch	2	
2	2008983CG	Throttle Bracket	1	
3	26719CG	Angle for Actuator Assembly	1	
4	28377CG	Adjustment Plate	1	



## Seed Chariot 1020 — Parts

### U-Joint, Pulley, Engine, & Battery Components

Please visit [www.unverferth.com/parts/](http://www.unverferth.com/parts/) for the most current parts listing.

ITEM	PART NO.	DESCRIPTION	QTY	NOTES
5	28418B	Battery Bracket	2	
6	28419CG	Battery Cover	1	
7	29157CG	Shield Weldment	1	
8	29160CG	Outer Shield Weldment	1	
9	29275CG	Engine Mount Weldment	1	
10	29294	Shaft - Keyed	1	
11	29378CG	Shield Assembly	1	
12	800713	Key 1/4 x 1/4 x 1 1/2	2	
13	9001396	Self Drilling Screw #10-16 x 1/2"	1	
14	9001501	Key 1/4" x 1/4" x 1"	1	
15	900513	Grommet 1 3/4" ID	2	
16	901659	Pulley/Sheave w/ Set Screws	1	
17	901673	Honda Engine 4.8 Net HP Gas, 9.9 Cu. In.	1	
	901333	Key/Ignition Replacement	-	
	903057	Key on Output Shaft	-	
18	902059	Pulley 2.95 Dia. w/ Set Screws	1	
19	902775	Battery 12V	1	
20	903115	Belt	1	
21	903165	U-Joint	1	
22	91256	Large Flange Screw 5/16-18UNC x 3/4	4	
23	91257	Flange Nut 5/16-18UNC	8	
24	91263	Large Flange Nut 3/8-16UNC	4	
25	9388-024	Carriage Bolt 5/16-18UNC x 3/4	4	
26	9388-027	Carriage Bolt 5/16-18UNC x 1 1/2	2	
27	9388-051	Carriage Bolt 3/8-16UNC x 1	4	
28	9390-007	Capscrew 1/4-20UNC x 1 1/2	2	
	9390-008	Capscrew 1/4-20UNC x 1 3/4	1	
29	9390-045	Capscrew 5/16-18UNC x 5 1/2	3	
30	9390-100	Capscrew 1/2-13UNC x 1 1/4	2	
31	9390-102	Capscrew 1/2-13UNC x 1 3/4	2	
32	9394-002	Hex Nut 1/4"-20UNC	1	
33	9394-004	Hex Nut 5/16-18UNC	2	
34	9395-010	Hex Jam Nut 1/2-13UNC	1	
35	9404-019	Lock Washer 5/16"	2	
36	9405-064	Flat Washer 1/4" USS	1	
37	9405-086	Flat Washer 1/2 SAE	3	
38	9500341	Carriage Bolt 5/16-18UNC x 1 3/4 Full Threaded	4	
39	9500551	Battery Cable (Red)	1	
40	9500552	Battery Cable (Black)	1	
41	2008982	Actuator Replacement Kit	1	
42	97048	Decal, WARNING "Pinch Point"	1	
43	9800	Locknut 1/2-13UNC	4	
44	9807	Locknut 5/16-18UNC	3	
45	9936	Locknut 1/4-20UNC	3	
46	TA0-903088-0	Bearing w/Flange 1" ID	2	
47	TA0-907228-0	Capscrew 1/2-13UNC x 7 1/2 (Full Threaded)	1	
48	TA0-908394-0	Pop Rivets	4	
49	TA1-906109-0	Decal, WARNING "Moving Parts"	1	

Auger Discharge End Components

Please visit [www.unverferth.com/parts/](http://www.unverferth.com/parts/) for the most current parts listing.

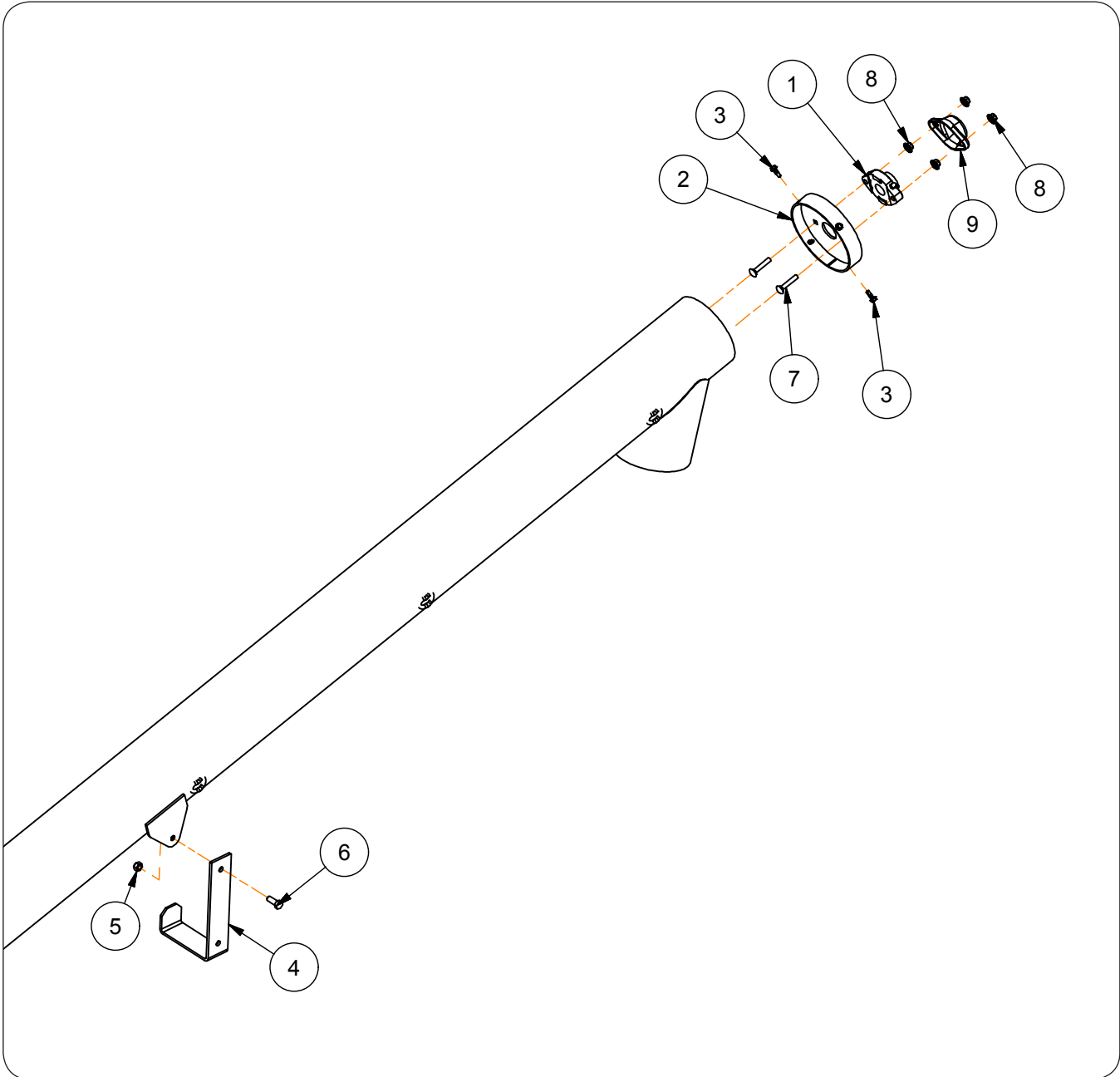

**Auger Discharge End Components**

Please visit [www.unverferth.com/parts/](http://www.unverferth.com/parts/) for the most current parts listing.

ITEM	PART NO.	DESCRIPTION	QTY	NOTES
1	TA0-903088-0	Bearing w/Flange 1" I.D.	1	
2	29405CG	End Cap	1	
3	9473	Self-Drilling Screw 1/4-14 x 3/4	4	
4	24414CG	Spout Bracket	1	
5	9928	Locknut 3/8-16UNC	1	
6	9390-055	Capscrew 3/8-16UNC x 1	1	Grade 5
7	9500341	Carriage Bolt 5/16-18UNC x 1 3/4	2	Grade 5
8	91257	Large Flange Nut 5/16-18UNC	4	
9	9500310	Bearing Cover	1	

# Seed Chariot 1020 — Parts

## Pivot Arm Components

Please visit [www.unverferth.com/parts/](http://www.unverferth.com/parts/) for the most current parts listing.

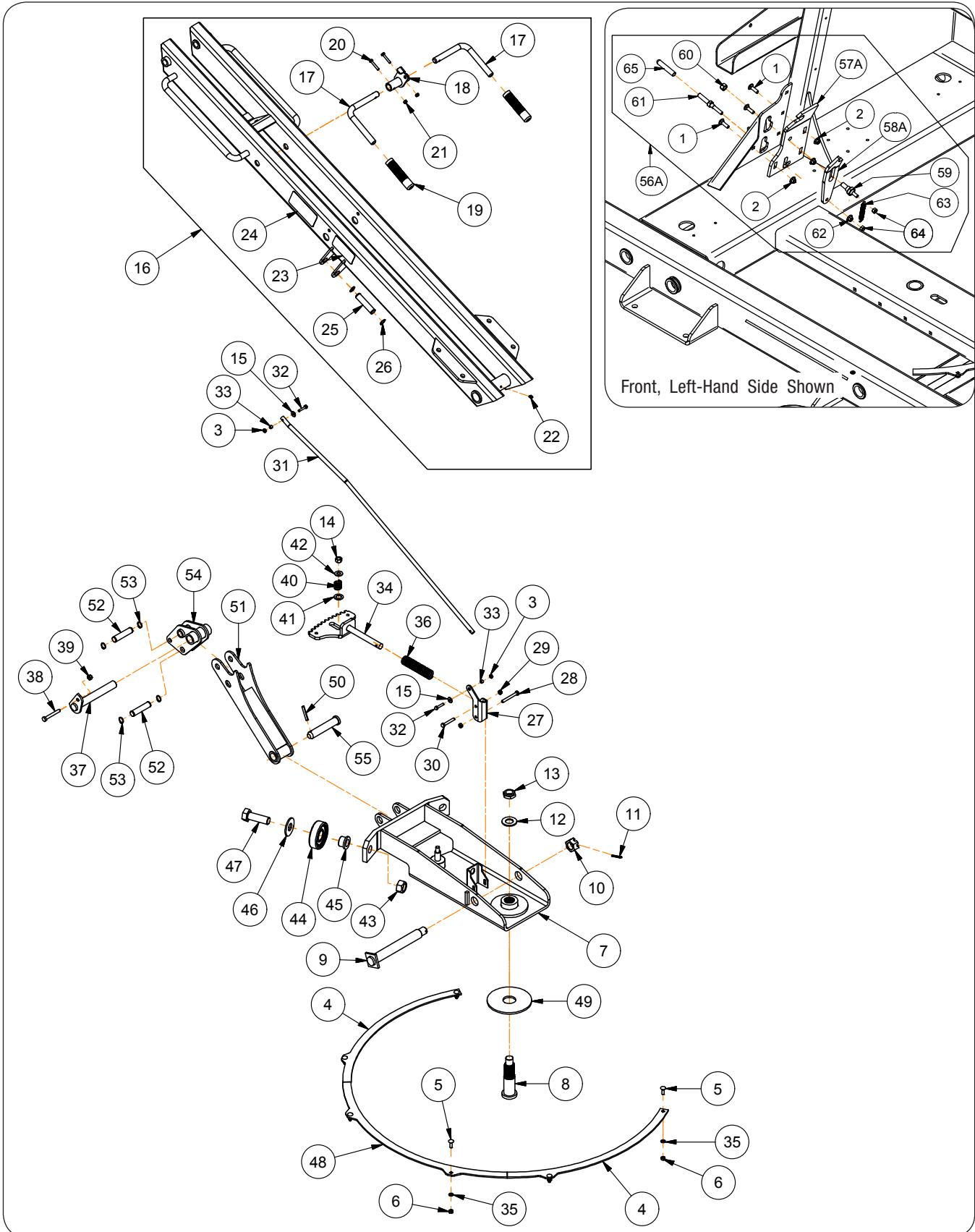

## Seed Chariot 1020 — Parts

### Pivot Arm Components

Please visit [www.unverferth.com/parts/](http://www.unverferth.com/parts/) for the most current parts listing.

ITEM	PART NO.	DESCRIPTION	QTY	NOTES
1	9388-052	Carriage Bolt 3/8-16UNC x 1 1/4	6	Grade 5
2	91263	Flange Nut 3/8-16UNC	6	
3	9936	Locknut 1/4-20UNC	2	
4	24863	Plate/Segment	2	
5	9388-025	Carriage Bolt 5/16-18UNC x 1	6	Grade 5
6	9394-004	Hex Nut 5/16-18UNC	6	
7	29032CG	Pivot Weldment	1	
8	29968	Splined Shaft 2" Dia.	1	
9	27512	Pin Weldment	1	
10	9393-020	Slotted Nut 1-14UNS	1	
11	9391-035	Cotter Pin 5/32" Dia. x 1 1/2	1	
12	9405-116	Flat Washer 1"	1	
13	96976-040	Thin Locknut 1-14UNS	1	
14	9800	Locknut 1/2-13UNC	9	
15	9405-064	Flat Washer 1/4 USS	2	
16	29486CG	Arm Assembly w/Decals	1	Includes Items 17 through 26
17	24023CG	Handle	2	
18	29178CG	Cam Weldment	1	
19	92928	Hand Grip 3/4" ID	2	
20	9390-007	Capscrew 1/4-20UNC x 1 1/2	2	
21	9936	Locknut 1/4-20UNC	2	
22	91160	Grease Zerk	1	
23	95839	Decal, WARNING (Pinch Point)	2	
24	98229	Decal, WARNING (Lower Equipment)	2	
25	29248	Pin 3/4" Dia.	2	
26	903145-018	Retaining Ring 3/4" Nom.	4	
27	29179CG	Bracket	1	
28	9390-037	Capscrew 5/16-18UNC x 2 3/4	1	Grade 5
29	9807	Locknut 5/16-18UNC	2	
30	9390-034	Capscrew 5/16-18UNC x 2	1	
31	29180CG	Push Rod	1	
32	9390-006	Capscrew 1/4-20UNC x 1 1/4	2	Grade 5
33	22018	Bushing 3/8" OD	2	
34	28453CG	Latch Weldment	1	
35	9404-019	Lock Washer 5/16"	6	
36	902616	Spring 5" Long	1	
37	28526	Pin Weldment 1" Dia.	1	
38	9390-062	Capscrew 3/8-16UNC x 2 3/4	1	Grade 5
39	9928	Locknut 3/8-16UNC	1	
40	902602	Spring 1" Long	1	

(Continued on next page)

## Seed Chariot 1020 — Parts

### Pivot Arm Components (continued)

Please visit [www.unverferth.com/parts/](http://www.unverferth.com/parts/) for the most current parts listing.

ITEM	PART NO.	DESCRIPTION	QTY	NOTES
41	9500091	Nylon Washer	1	
42	9405-086	Flat Washer 1/2" SAE	1	
43	9663	Top Locknut 1-8"UNC	2	
44	2000189	Bearing Assembly	2	
45	23951	Bushing	2	
46	9405-118	Flat Washer 1" USS	2	
47	9390-187	Capscrew 1-8UNC x 3	2	Grade 5
48	2001301	Plate/Segment	1	
49	901186	Poly Washer	1	
50	9392-159	Roll Pin 5/16" Dia. x 2	2	
51	29168CG	Pivot Link Weldment (Long)	1	
52	27922	Pin 3/4" Dia. x 3 1/4	2	
53	903145-018	Retaining Ring-External 3/4"	4	
54	29170CG	Pivot Link Weldment (Short)	1	
55	9500423	Pin 1" Dia. x 5 1/8	1	
56A	29220CG	Latch Assembly LH	1	Includes 57A through 65
56B	29221CG	Latch Assembly RH	1	Includes 57B through 65
57A	29200CG	Latch Plate LH	1	
57B	29201CG	Latch Plate RH	1	
58A	29217CG	Inside Plate LH	1	
58B	29218CG	Inside Plate RH	1	
59	29209	Double Threaded Pin	2	
60	29219	Latch Pin	2	
61	91263	Flange Nut 3/8-16UNC	2	
62	9800	Locknut 1/2-13UNC	2	
63	903141	Extension Spring	2	
64	9928	Locknut 3/8-16UNC	4	
65	902603	Hand Grip	2	

**Notes**

Electric Conveyor Lift Package #2000623

Please visit [www.unverferth.com/parts/](http://www.unverferth.com/parts/) for the most current parts listing.

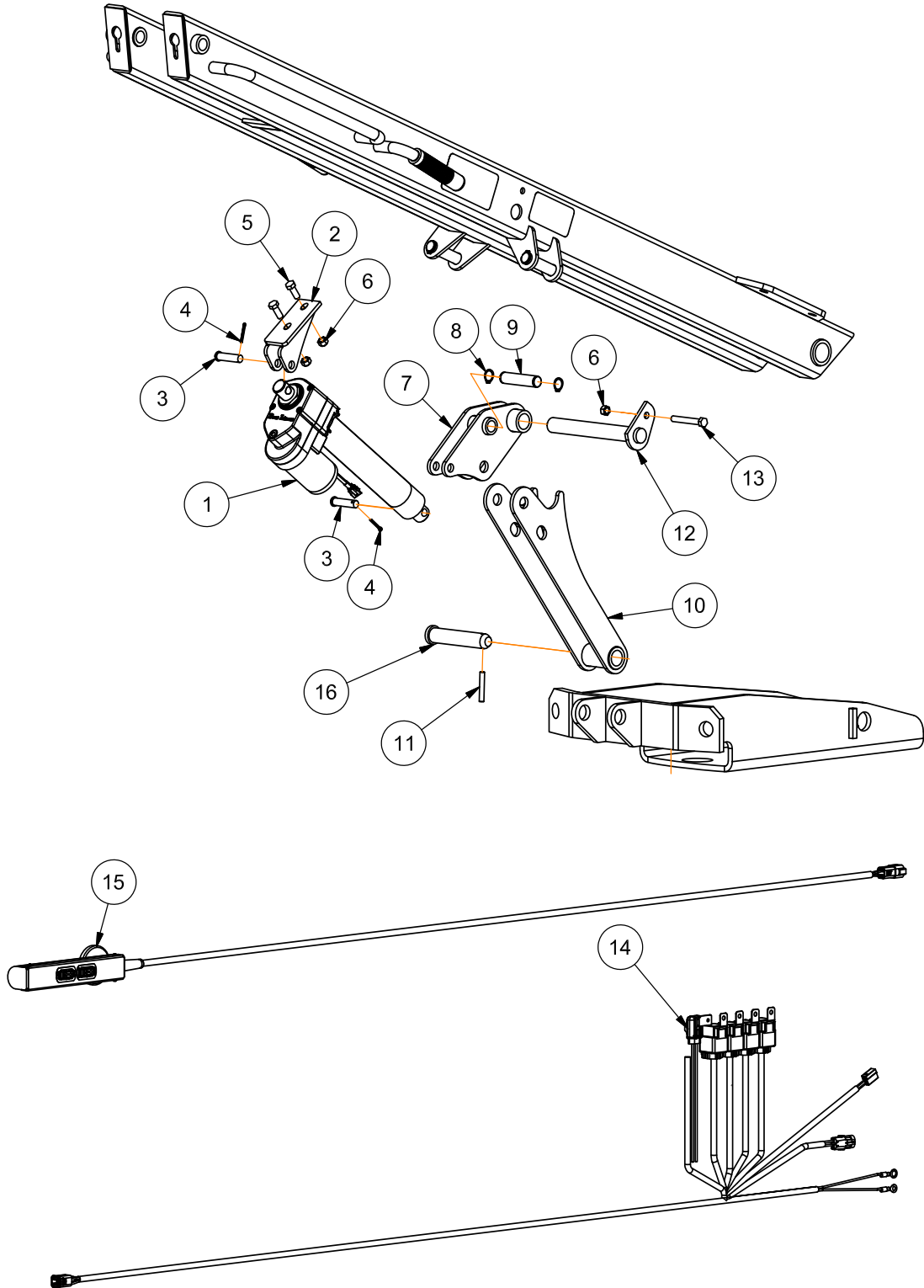



## Seed Chariot 1020 — Parts

### Electric Conveyor Lift Package #2000623

Please visit [www.unverferth.com/parts/](http://www.unverferth.com/parts/) for the most current parts listing.

ITEM	PART NO.	DESCRIPTION	QTY.	NOTES
1	903116	Electric Actuator	1	
2	2009372CG	Clevis Weldment	1	
3	902280	Clevis Pin 1/2" Dia. x 2 5/32	2	
4	9391-023	Cotter Pin 1/8" Dia. x 1	2	
5	9390-055	Capscrew 3/8-16UNC x 1	2	Grade 5
6	9928	Locknut 3/8-16UNC	3	
7	29170CG	Pivot Link Weldment Short	1	
8	903145-018	Retaining Ring - External 3/4"	2	
9	29248	Pin 3/4" Dia. x 3 1/4	1	
10	29168CG	Pivot Link Weldment Long	1	
11	9392-159	Roll Pin 5/16" Dia. x 2	1	
12	28526	Pin Weldment	1	
13	9390-062	Capscrew 3/8-16UNC x 2 3/4	1	Grade 5
14	2000588	2-Function Wire Harness	1	
15	2000617	Switch Assembly	1	
16	9500423	Pin 1" Dia. x 5 1/8	1	

Platform Components

Please visit [www.unverferth.com/parts/](http://www.unverferth.com/parts/) for the most current parts listing.

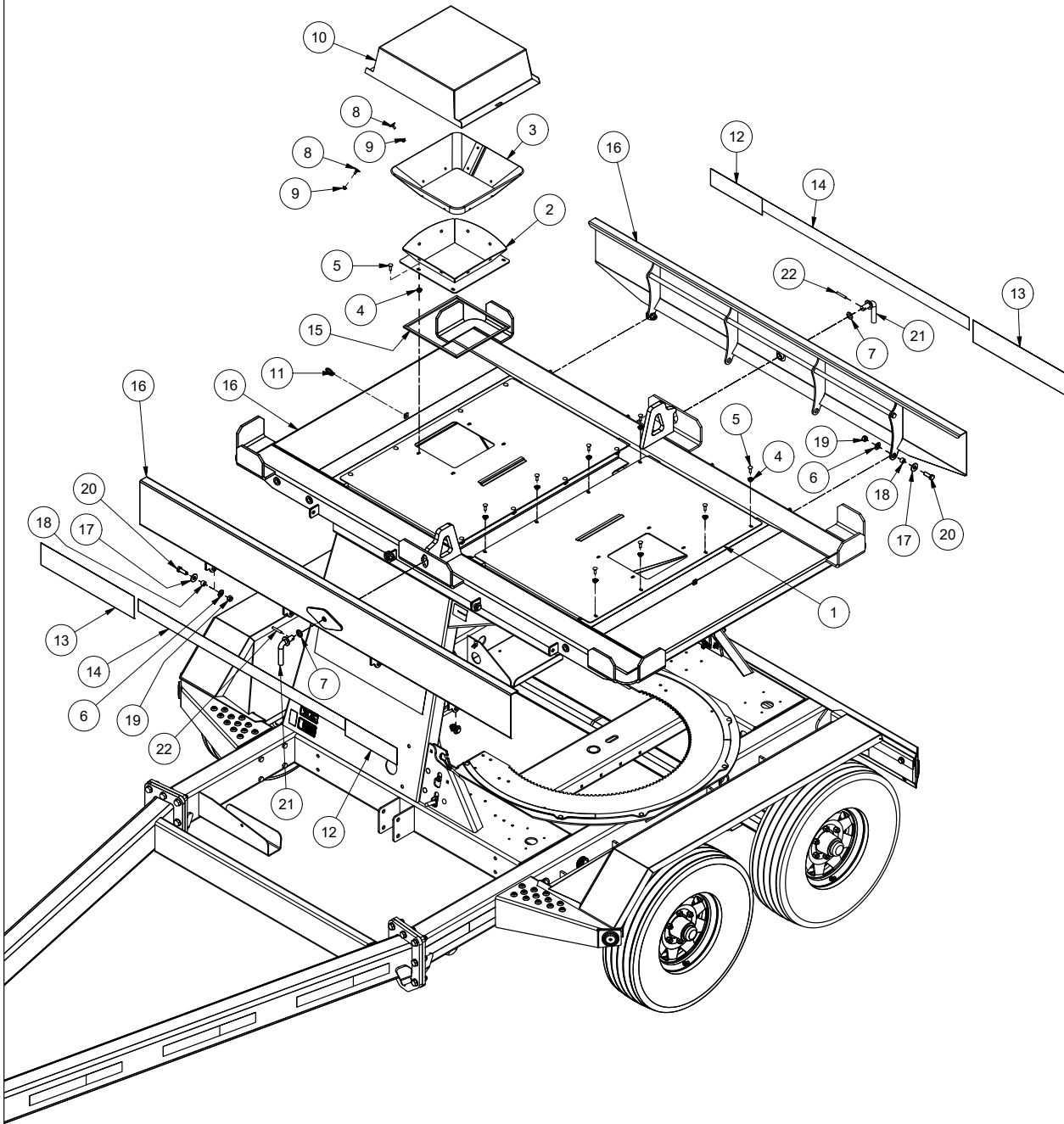

## Seed Chariot 1020 — Parts

### Platform Components

Please visit [www.unverferth.com/parts/](http://www.unverferth.com/parts/) for the most current parts listing.

ITEM	PART NO.	DESCRIPTION	QTY	NOTES
1	2010229DG	Platform Cover =Dove Grey=	2	
2	27825DG	Hopper Weldment =Dove Grey=	2	
3	27826	Rubber Hopper	2	
4	91257	Large Flange Hex Nut 5/16"-18UNC	24	
5	9388-025	Carriage Bolt 5/16"-18UNC x 1"	24	Grade 5
6	903108	Flat Washer, 5/8" (Stainless Steel)	2	
7	9500091	Nylon Washer, 3/4"	4	
8	902006	Elevator Bolt 1/4"-20UNC x 3/4"	18	
9	97189	Large Flange Hex Nut 1/4"-20UNC	18	
10	27827CG	Hopper Cover =Charcoal Grey=	2	
11	9093	Klik Pin 3/16" Dia.	2	
12	9500463	Decal, Model 1020	2	
13	902934	Decal, Seed Chariot	2	
14	902936	Decal Stripe	2	
15	900152	Foam Rubber	1	
16	29030DG	Side Panel Weldment =Dove Grey=	2	
17	9405-088	Flat Washer 1/2" USS	8	
18	24550	Bushing 1/2" Long	8	
19	9800	Locknut 1/2"-13UNC	8	
20	9390-101	Capscrew 1/2"-13UNC x 1 1/2"	8	Grade 5
21	2001336	Pin Weldment	2	
22	91144-186	Spiral Pin 5/16" Dia. x 2"	2	

# Seed Chariot 1020 — Parts

## Undercarriage, Hitch & Fender Components

Please visit [www.unverferth.com/parts/](http://www.unverferth.com/parts/) for the most current parts listing.

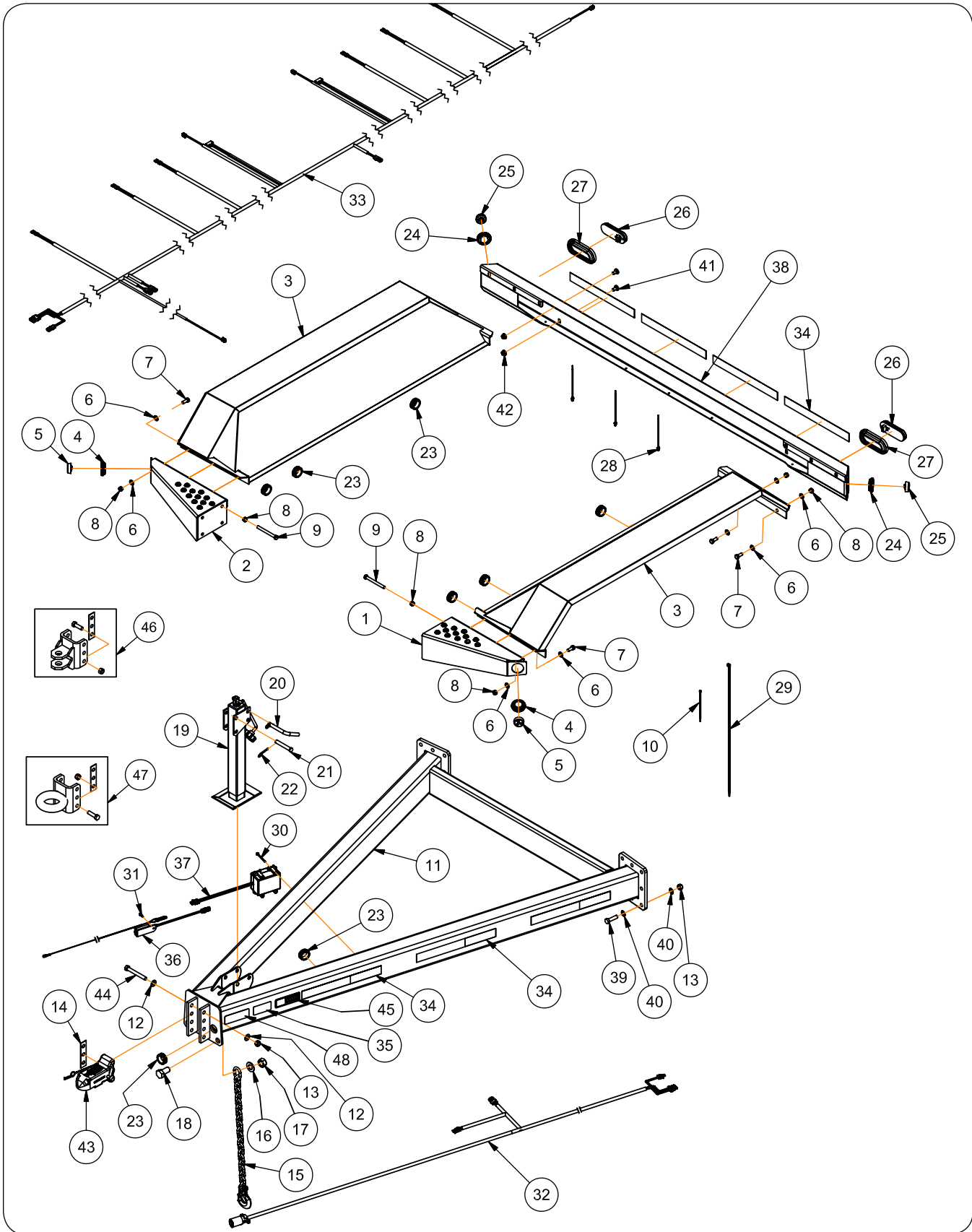

## Seed Chariot 1020 — Parts

### Undercarriage, Hitch & Fender Components

Please visit [www.unverferth.com/parts/](http://www.unverferth.com/parts/) for the most current parts listing.

ITEM	PART NO.	DESCRIPTION	QTY	NOTES
1	29237CG	Fender Step/Mount LH	1	
2	29238CG	Fender Step/Mount RH	1	
3	29240CG	Fender Weldment	2	
4	900956	Grommet	8	
5	900954	Light/Amber (Round)	2	
6	9405-086	Flat Washer 1/2" SAE	22	
7	9390-100	Capscrew 1/2-13UNC x 1 1/4	14	Grade 5
8	9800	Locknut 1/2-13UNC	16	
9	9390-113	Capscrew 1/2-13UNC x 5	8	
10	9000106	Cable Tie 6" Long	A/R	
11	24995CG	Hitch Weldment 8' Undercarriage	1	
12	9405-098	Flat Washer 5/8" SAE	6	
13	9801	Locknut 5/8-11UNC	27	
14	25347B	Shim	2	
15	98792	Chain w/Hook & C-Link Asy	2	
16	9405-116	Flat Washer 1" SAE	2	
18	9663	Locknut 1-8UNC	2	
18	91299-183	Capscrew 1-8UNC x 2	2	Grade 8
19	902326	Jack Stand Weldment 8000#	1	
20	84979	Bent Pin 5/8" Dia.	1	
21	9805	Clevis Pin 5/8" Dia. x 4	1	
22	9806	Hairpin Cotter .148" Dia. x 2.687	1	
23	98487	Grommet 1 3/4" Dia.	8	
24	900956	Grommet	2	
25	900955	Light/Red (Round)	2	
26	97180	Light/Red (Oval)	2	
27	97182	Grommet	2	
28	99599	Cable Tie 8.39" Long	A/R	
29	94038	Cable Ties 32" Long	A/R	
30	902238	Flange Bolt 1/4-20UNC x 3 (Grade 5)	4	
31	9512	Screw/Self Drill 1/4-14 x 1	2	
32	25045	Front Wiring Harness 165"	1	
33	25046	Rear Wiring Harness 352"	1	
34	25003	Conspicuity Marking 18"	10	
35	97961	Decal WARNING (Read & Understand Manual)	1	

(Continued on next page)

## Seed Chariot 1020 — Parts

### Undercarriage, Hitch & Fender Components (continued)

Please visit [www.unverferth.com/parts/](http://www.unverferth.com/parts/) for the most current parts listing.

TEM	PART NO.	DESCRIPTION	QTY	NOTES
36	900786	Breakaway Electric Switch Complete	1	
37	902764	Battery w/Charger & Box	1	
38	29230CG	Light Bar Weldment	1	
39	9390-125	Capscrew 5/8-11UNC x 2 1/4	16	Grade 5
40	903108	Flat Washer 5/8" (Stainless Steel)	40	
41	9388-102	Capscrew 1/2-13UNC x 1	4	Grade 5
42	91267	Flange Nut 1/2-13UNC	4	
43	9500289CG	Hitch 2 5/16" Ball	1	
	2000357CG	Ball Hitch Kit with Mounting Hardware	-	
44	9390-134	Capscrew 5/8-11UNC x 5	3	Grade 5
45	9500710	Decal CAUTION (Transport Chains)	1	
46	2000264B	Optional Clevis Hitch Kit	-	
47	2000265B	Optional Pintle Hitch Kit	-	
48	9500345	Decal, CAUTION (Towing...)	1	

**Notes**

# Seed Chariot 1020 — Parts

## Axle & Wheel Components

Please visit [www.unverferth.com/parts/](http://www.unverferth.com/parts/) for the most current parts listing.

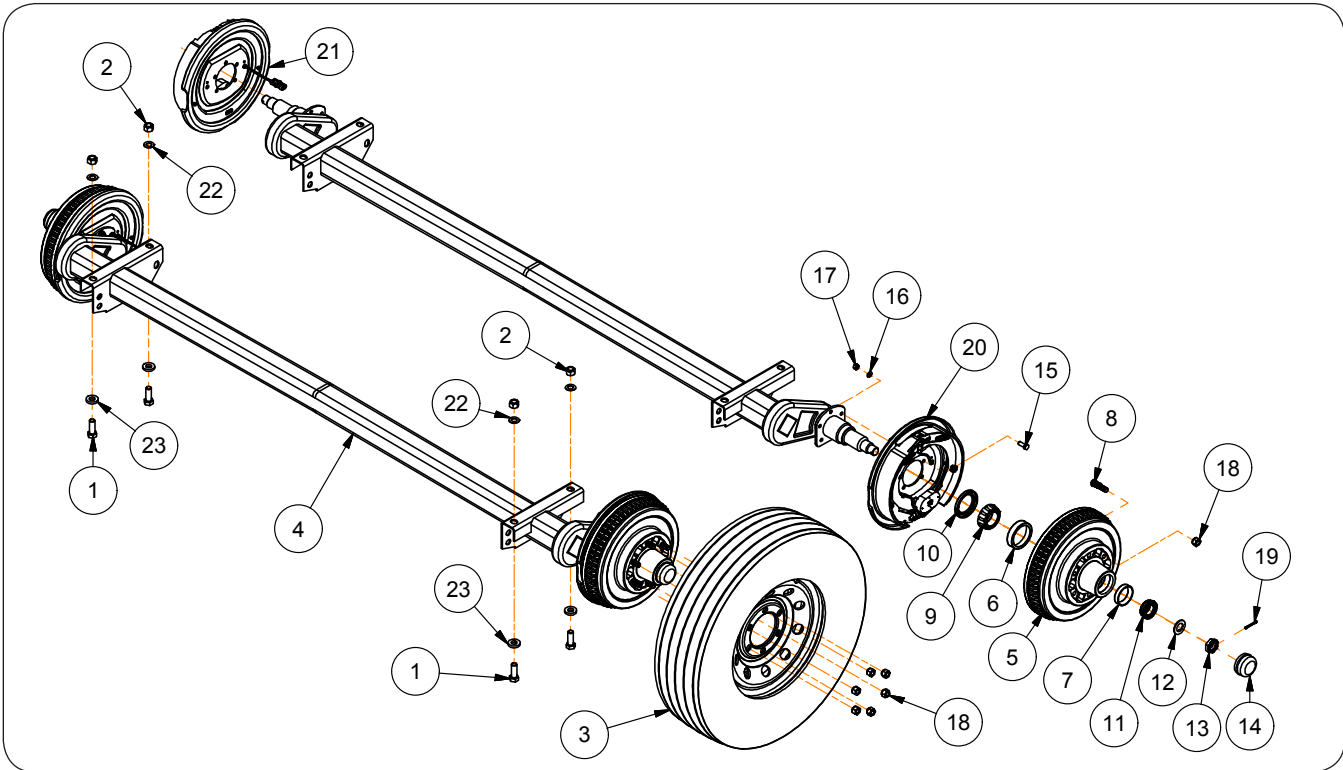

ITEM	PART NO.	DESCRIPTION	QTY	NOTES
1	9390-123	Capscrew 5/8-11UNC x 1 3/4	8	Grade 5
2	9801	Locknut 5/8-11UNC	8	
3	98115	Wheel/Tire	4	
4	903052B	Torsion Axle Assembly w/Brakes	2	Includes Items 5 through 21
5	900767B	Hub 6 Bolt Sub Assy with Cups & Studs	4	Includes Items 6 through 8
6	91812	Bearing Cup (25520)	4	
7	91813	Bearing Cup (15245)	4	
8	97346	Stud Bolt 1/2-20UNF x 2 (Grade 8)	24	
9	91822	Bearing Cone (25580)	4	
10	97342	Seal 2 1/4 ID x 3.376 OD	4	
11	91823	Bearing Cone (15123)	4	
12	97343	Washer/Key 1.032 ID	4	
13	97344	Slotted Jam Nut 1-14UNS	4	
14	97345	Hub Cap	4	
15	9390-055	Capscrew 3/8-16UNC x 1	16	Grade 5
16	9404-021	Lock Washer 3/8"	16	
17	9394-006	Hex Nut 3/8-16UNC	16	
18	91875	Tapered Nut 1/2-20UNF	24	
19	9391-035	Cotter pin 5/32" Dia x 1 1/2	4	
20	97348	Electric Brake Cluster, LH	2	
21	97349	Electric Brake Cluster, RH	2	
22	903108	Flat Washer 5/8" (Stainless Steel)	8	
23	9746	Flat Washer 5/8"	8	



## Spare Tire Kit Components

Please visit [www.unverferth.com/parts/](http://www.unverferth.com/parts/) for the most current parts listing.

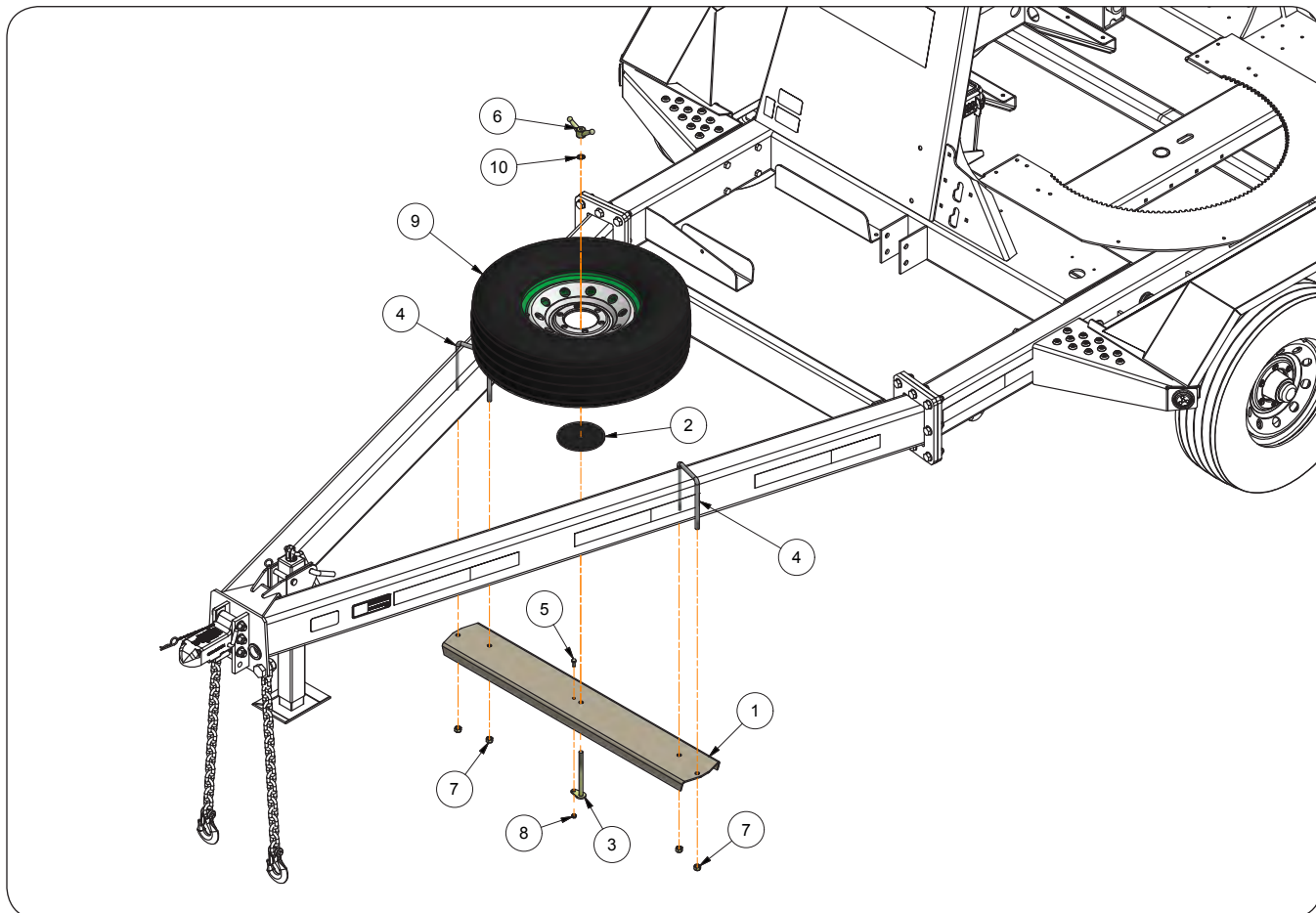

ITEM	PART NO.	DESCRIPTION	QTY	NOTES
	2000622B	Spare Tire Kit	-	Includes Items 1 through 10
1	29736B	Mounting Plate	1	
2	29744B	Washer	1	
3	29751	Pin Weldment 1/2" Dia. x 6 5/8	1	
4	91323	U-Bolt 1/2-13UNC x 7 1/8	2	
5	9390-028	Capscrew 5/16-18UNC x 3/4	1	Grade 5
6	9500475	Handle Wing Nut 1/2-13UNC	1	
7	9800	Locknut 1/2-13UNC	4	
8	9807	Locknut 5/16-18UNC	1	
9	98115	Tire & Wheel Assembly (6 x 15)	1	TL225/75D15
10	TA500470	Lock Washer - External Tooth 1/2" I.D.	1	

**Telescopic Spout 2-Stage**

Please visit [www.unverferth.com/parts/](http://www.unverferth.com/parts/) for the most current parts listing.

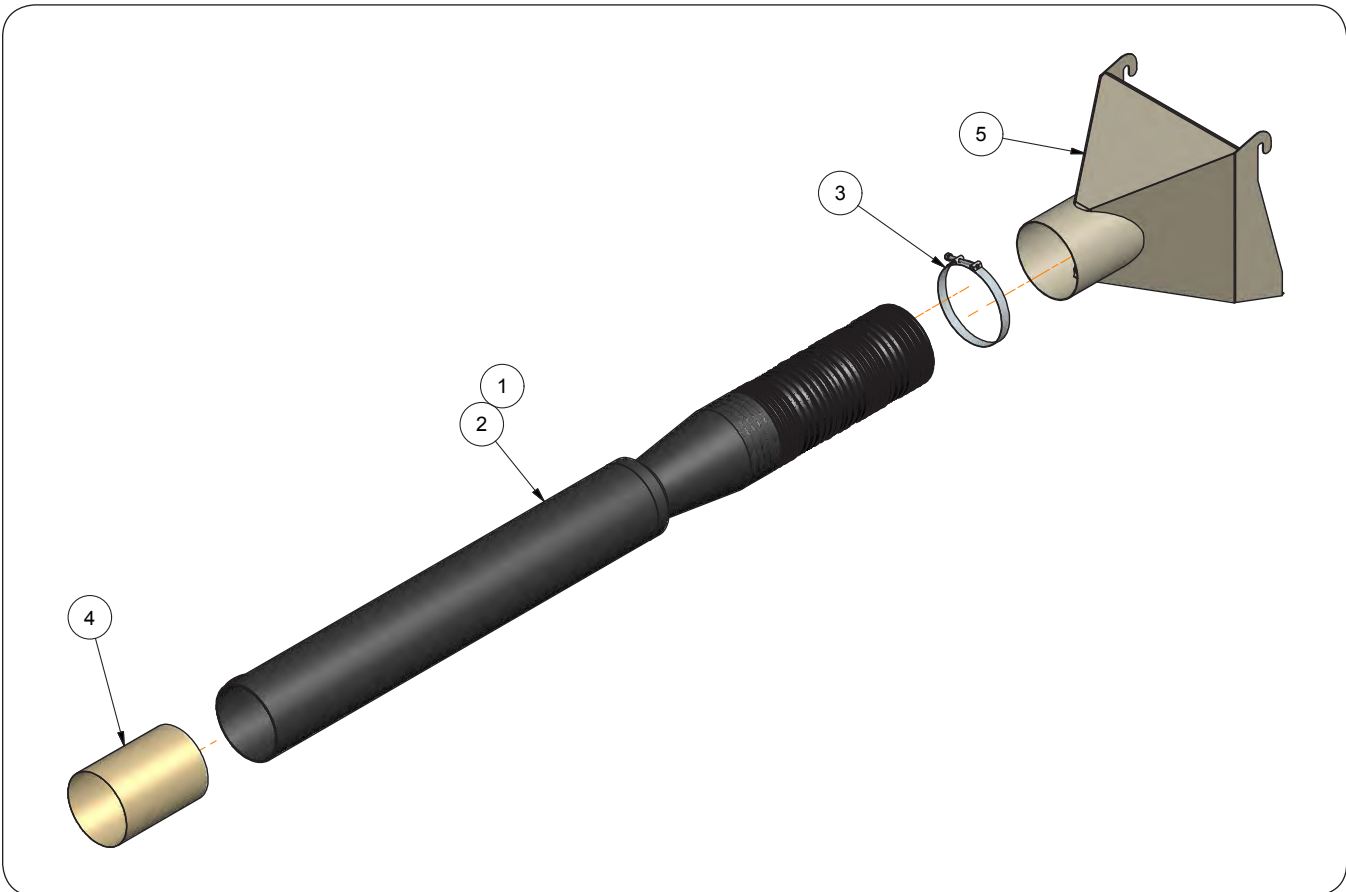

ITEM	PART NO.	DESCRIPTION	NOTES
1	27629	6" Conveyor Telescopic Spout (71" Extended; 51 1/2 Collapsed)	Includes Items 2 & 4
2	95870	Telescopic Spout	
3	98060	Clamp/T-Bolt	
4	22577	Sock Spout Extension	
5	26585CG	Spout Weldment	

**Telescopic Spout 3-Stage**

Please visit [www.unverferth.com/parts/](http://www.unverferth.com/parts/) for the most current parts listing.

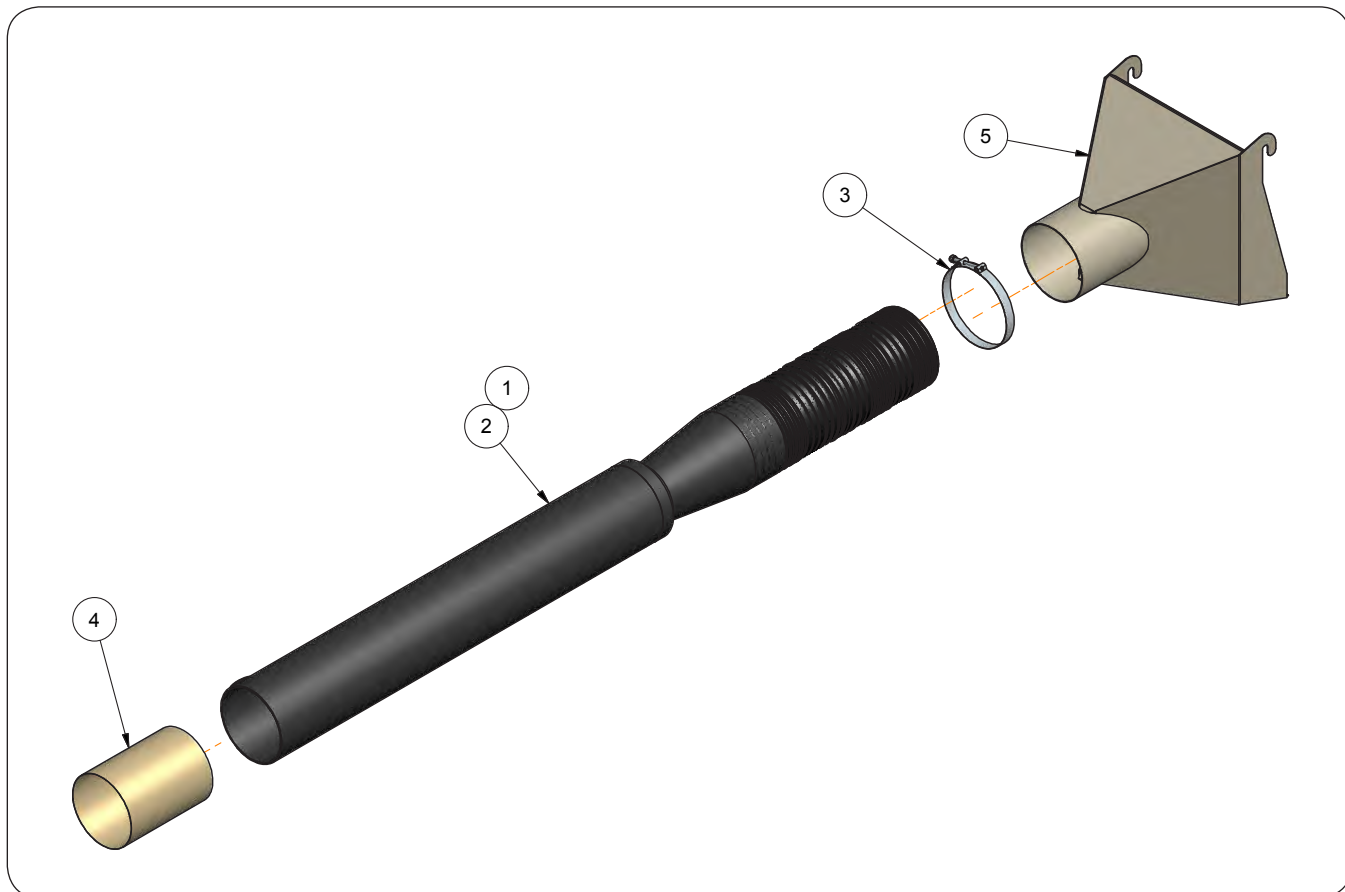

ITEM	PART NO.	DESCRIPTION	NOTES
1	22578	6" Conveyor Telescopic Spout 6'-10' ONLY	Includes Items 2, 3, 4
2	96855	Telescopic Spout	
3	98060	Clamp/T-Bolt	
4	22577	Sock Spout Extension	
5	26585CG	Spout Weldment	

# Seed Chariot 1020 — Parts

## Platform for Units Less Undercarriage Kit #2003134CG

Please visit [www.unverferth.com/parts/](http://www.unverferth.com/parts/) for the most current parts listing.

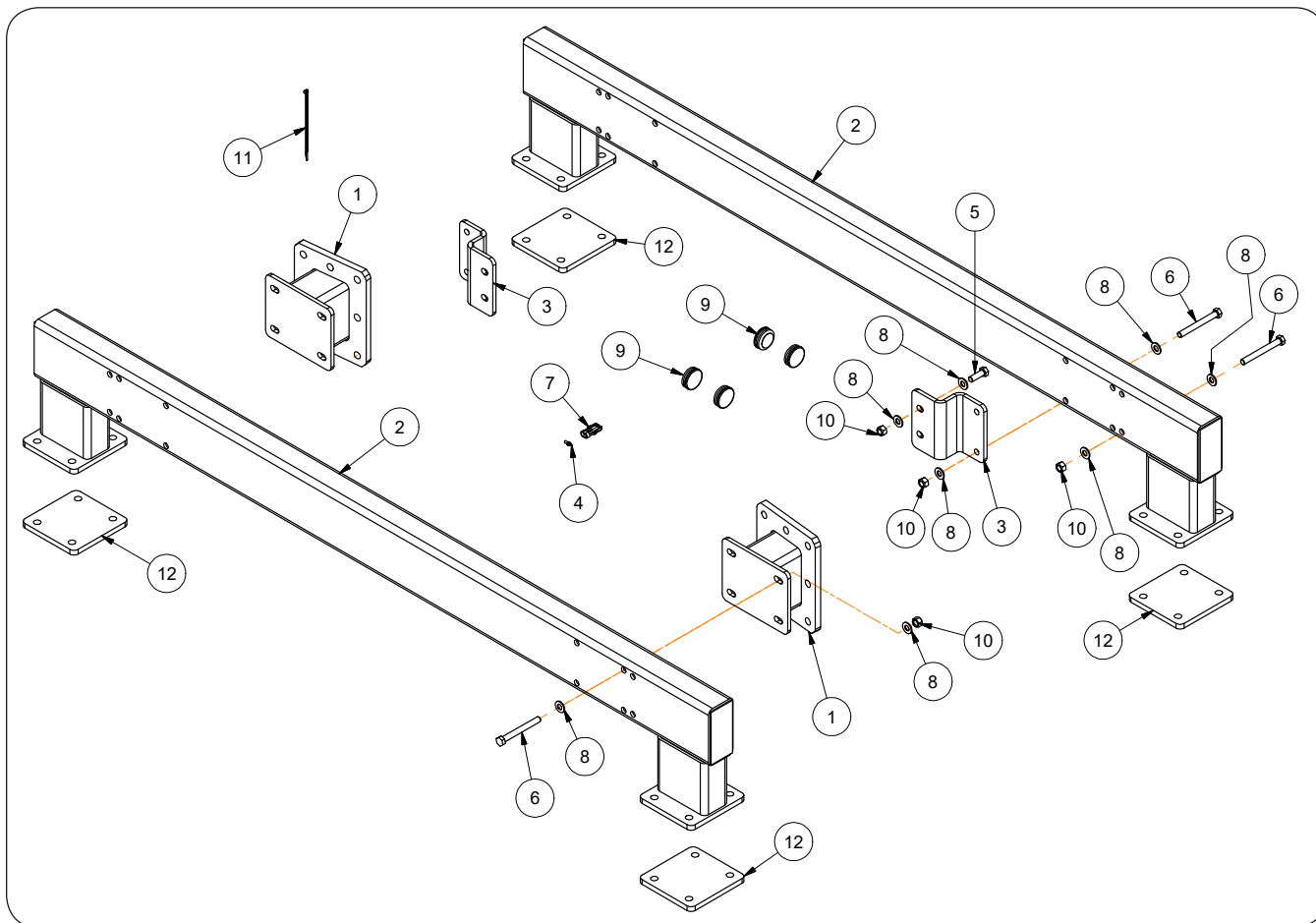

ITEM	PART NO.	DESCRIPTION	QTY	NOTES
1	2003078CG	Adapter Bracket Weldment =Charcoal Grey=	2	
2	2003079CG	Stand Weldment =Charcoal Grey=	2	
3	2003126CG	S-Bracket =Charcoal Grey=	2	
4	901710	Cavity Plug (Green)	2	
5	9390-101	Capscrew 1/2-13UNC x 1 1/2 (Grade 5)	4	
6	9390-112	Capscrew 1/2-13UNC x 4 1/2 (Grade 5)	16	
7	98004	Connector Assembly Shroud 2-Male Contacts	1	
8	9405-086	Flat Washer 1/2" SAE	40	
9	9501151	Round Plug	12	
10	9800	Locknut 1/2-13UNC	20	
11	9000106	Cable Tie 7 1/2" Long	1	
12	2003075B	Backer Plate	4	

# Seed Chariot 1020 — Parts

## AG Decal Package (Optional) - SMV, SIS Decals, & Reflectors

Please visit [www.unverferth.com/parts/](http://www.unverferth.com/parts/) for the most current parts listing.

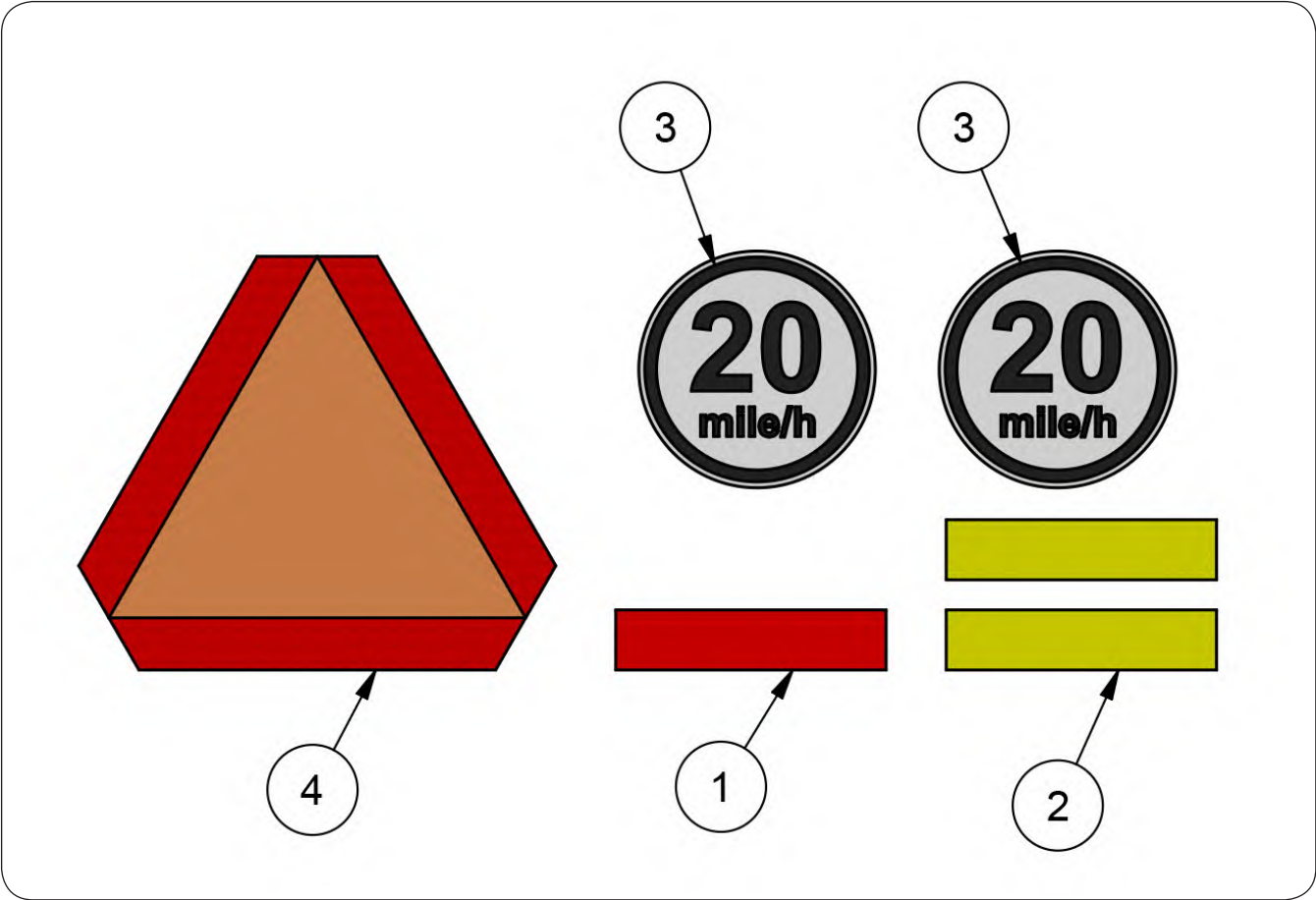

ITEM	PART NO.	DESCRIPTION	QTY.	NOTES
	2010513	AG Decal Package Option		
1	9003126	Reflector, RED	1	
2	9003127	Reflector, AMBER	2	
3	9008714	Decal, Rear SIS 20MPH	2	
4	97530	Decal, SMV Emblem	1	



***Unverferth***<sup>®</sup>

[www.unverferth.com](http://www.unverferth.com)